

A B C E F G

REV. NO.	DATE	DESCRIPTION	APP'D	REMARKS
1	-	-	-	-

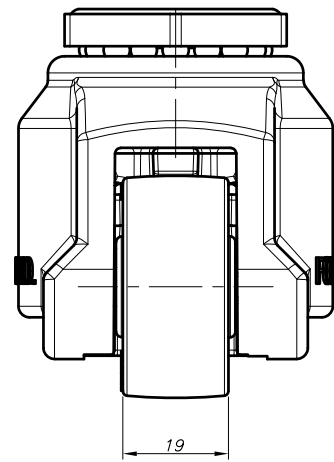
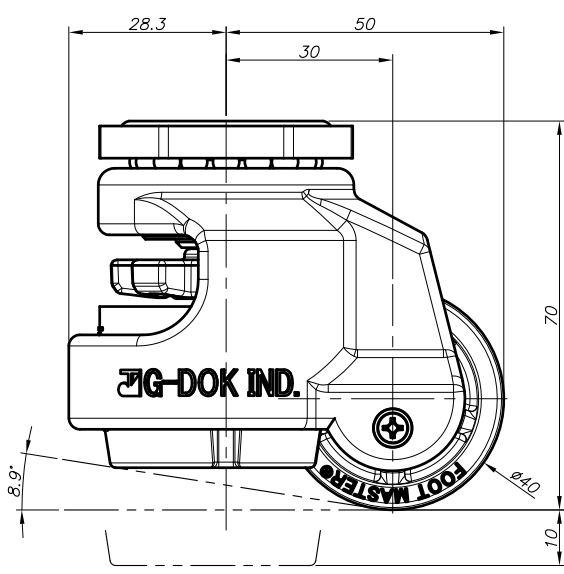
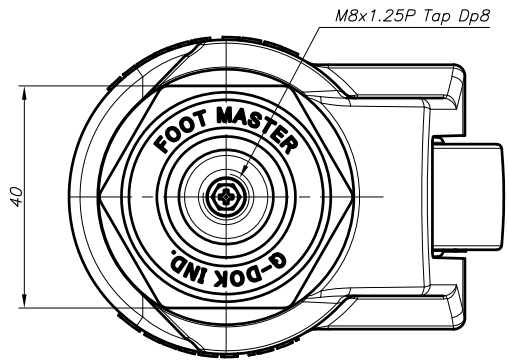
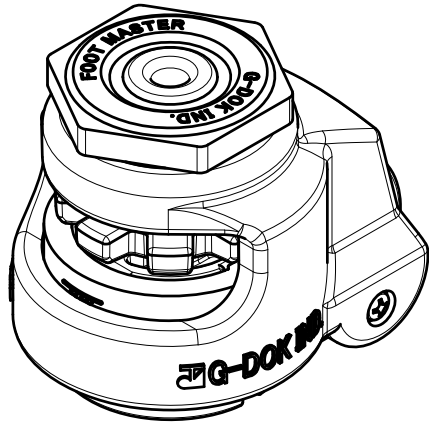

NO.	DESCRIPTION	UNIT	Q'TY	MATERIAL	WEIGHT	SPECIFICATION	REMARKS
-----	-------------	------	------	----------	--------	---------------	---------

PROCESS	--
MATERIAL	--
APPROVED BY	O.C.K
CHECKED BY	--
DRAWN BY	--

GENERAL TOLERANCE		CHAMFER	0.5	ROUND	0.5	UNIT	mm
MACHINING, BORING		(DE GRADING)		FLECTION MILLING			
RANGE	PRESION (T)	GRADE	RANGE	PRESION (T)	GRADE		
0.5 - 6	±0.05	±0.1	F-0	R5	R5		
6 - 30	±0.1	±0.2	F-0	R5	R5		
30 - 120	±0.15	±0.3	F-0	R5	R5		
120 - 400	±0.2	±0.5	F-0	R5	R5		
400 - 1000	±0.3	±0.8	F-0	R5	R5		

<b>FOOT MASTER®</b>		<b>FOOMA®</b>		<b>G-DOK IND.</b>	
SERIES NAME	LEVELING CASTER_GD-SERIES	DATE	2023.08.09	GSN NO.	-
PRODUCT NAME	GDN-40-S	SCALE	1/1	DWG. NO.	-
PART NAME	ASSEMBLY	WEIGHT	--	REVISION	
GENERAL TOLERANCE		B	ANGLE		⊕ ⊖

FOOT MASTER G-DOK IND. FOOT MASTER G-DOK IND.