

REV. NO.	DATE	DESCRIPTION	APP'D	REMARKS
△	-	-	-	-

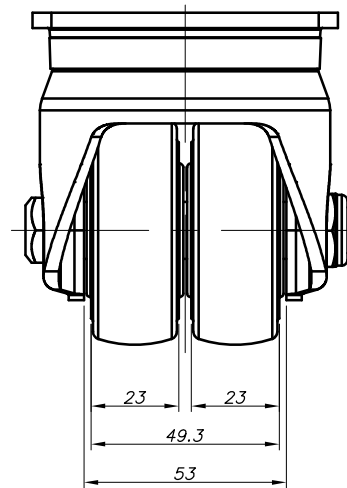
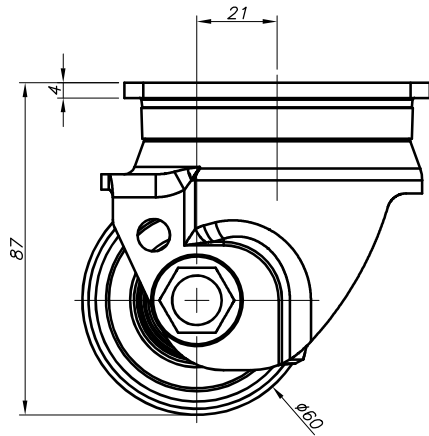
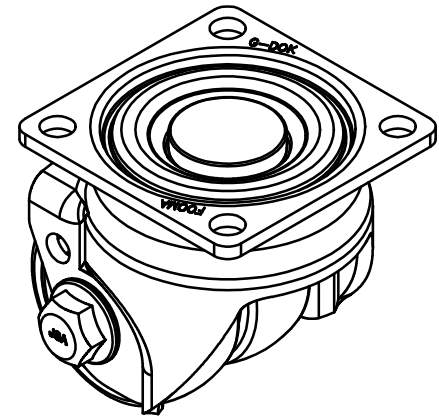
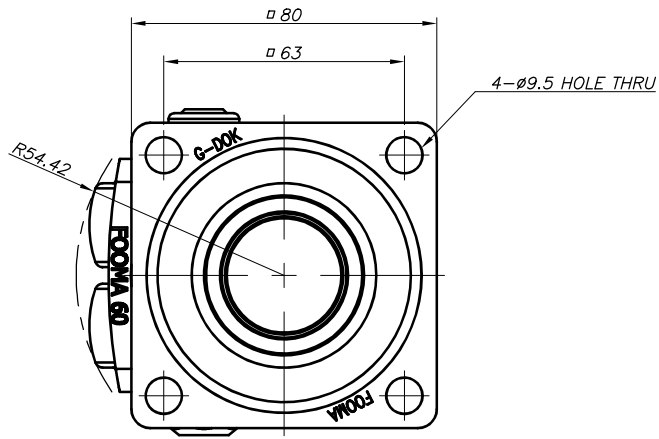

NOTE
※1) --

PROCESS			GENERAL TOLERANCE															
MATERIAL			MACHINE WORKING				DIE CASTING				WELDING				PRESS WORKING			
APPROVED BY	CHECKED BY	DRAWN BY	NAME	PRESION	DEVIA	NAME	PRESION	DEVIA	NAME	PRESION	DEVIA	NAME	PRESION	DEVIA	NAME	PRESION	DEVIA	
O.C.K	J.Y.H	J.Y.S	0.5-6	±0.05	±0.1	0.5-6	±0.1	±0.2	0.5-6	±0.1	±0.2	0.5-6	±0.1	±0.2	0.5-6	±0.1	±0.2	
			6-30	±0.1	±0.2	30-120	±0.15	±0.3	120-400	±0.2	±0.5	400-1000	±0.3	±0.8				
			CASTER HEIGHT	WELL OUTER DIAMETER	WELL INNER DIAMETER	WELL RADIUS												
			PRECISION	GENERAL	PRECISION	GENERAL	PRECISION	GENERAL	PRECISION	GENERAL	PRECISION	GENERAL	PRECISION	GENERAL				
			±0.05	±1%	±0.05	±1%	-1%	-2%	±0.1	±0.2	±0.1	±0.2	±0.1	±0.2				
			(MESH)mm	(MESH)mm	(MESH)mm	(MESH)mm	(MESH)mm	(MESH)mm	(MESH)mm	(MESH)mm	(MESH)mm	(MESH)mm	(MESH)mm	(MESH)mm				

NO.	DESCRIPTION	UNIT	Q'TY	MATERIAL	WEIGHT	SPECIFICATION	REMARKS
--	--	--	--	--	--	--	--

FOOT MASTER®			FOOMA®			G-DOK IND.		
SERIES NAME	AGV-SERIES	DATE	2023.07.28	GSN NO.	-			
PRODUCT NAME	GAUSD-60-ASF-HUD-PJP	SCALE	N/S	DWG. NO.	-			
PART NAME	ASSEMBLY	WEIGHT	--	REVISION				
		GENERAL TOLERANCE	B	ANGLE	△			