

REV. NO.	DATE	DESCRIPTION	APP'D	REMARKS
-	-	-	-	-

A
B
C
E
F
G

0

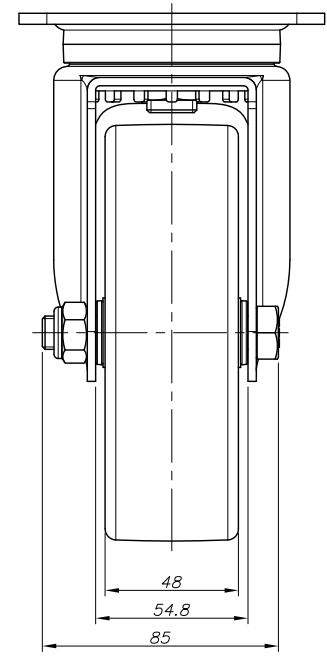
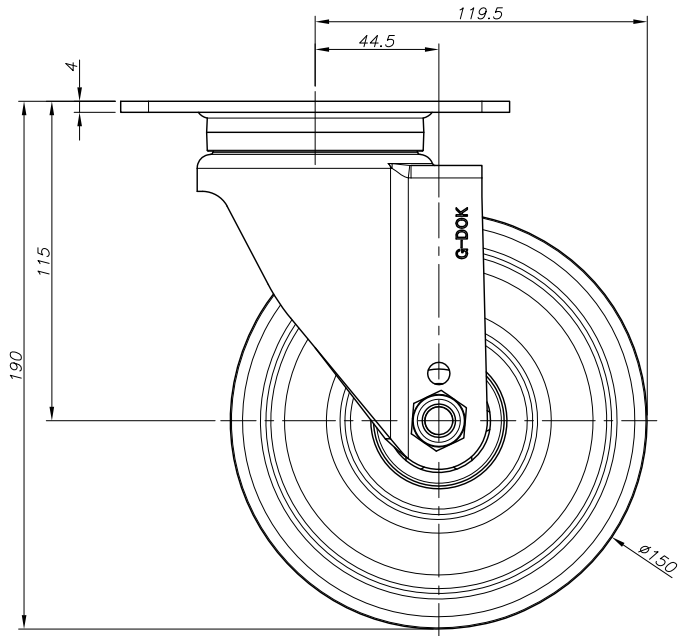
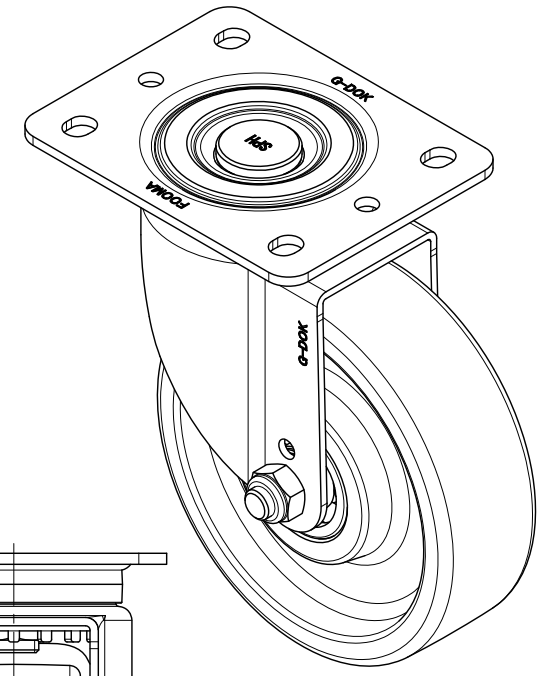
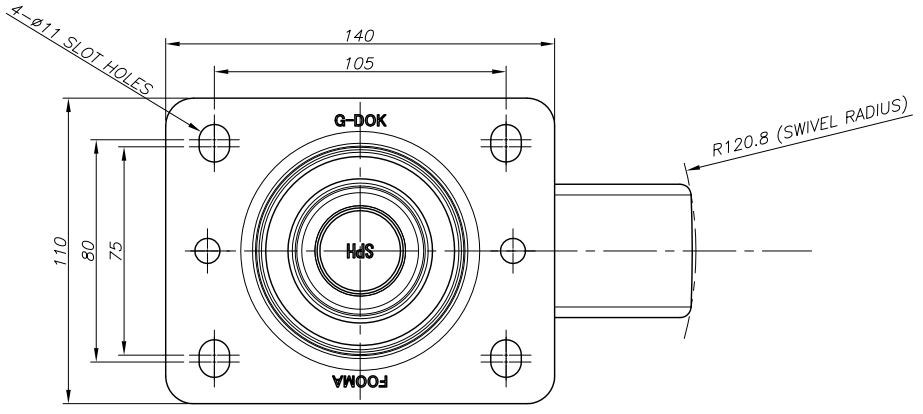

NOTE
1) MATERIAL : STAINLESS

NO.	DESCRIPTION	UNIT	Q'TY	MATERIAL	WEIGHT	SPECIFICATION	REMARKS
--	--	-	-	-	-	-	-

PROCESS		MATERIAL		APPROVED BY		CHECKED BY		DRAWN BY	
--		--		O.C.K		J.Y.H		K.S.J	

FOOT MASTER®		FOOMA®		G-DOK IND.	
SERIES NAME	SPH-SERIES	DATE	2026.05.18	GSN NO.	4H313-211111
PRODUCT NAME	SPH-150-ASF-NYD-PEU	SCALE	1/2	DWG. NO.	4H313-211111
PART NAME	ASSEMBLY	WEIGHT	--	REVISION	SIZE A3
GENERAL TOLERANCE		B		ANGLE	

FOOT MASTER G-DOK IND.

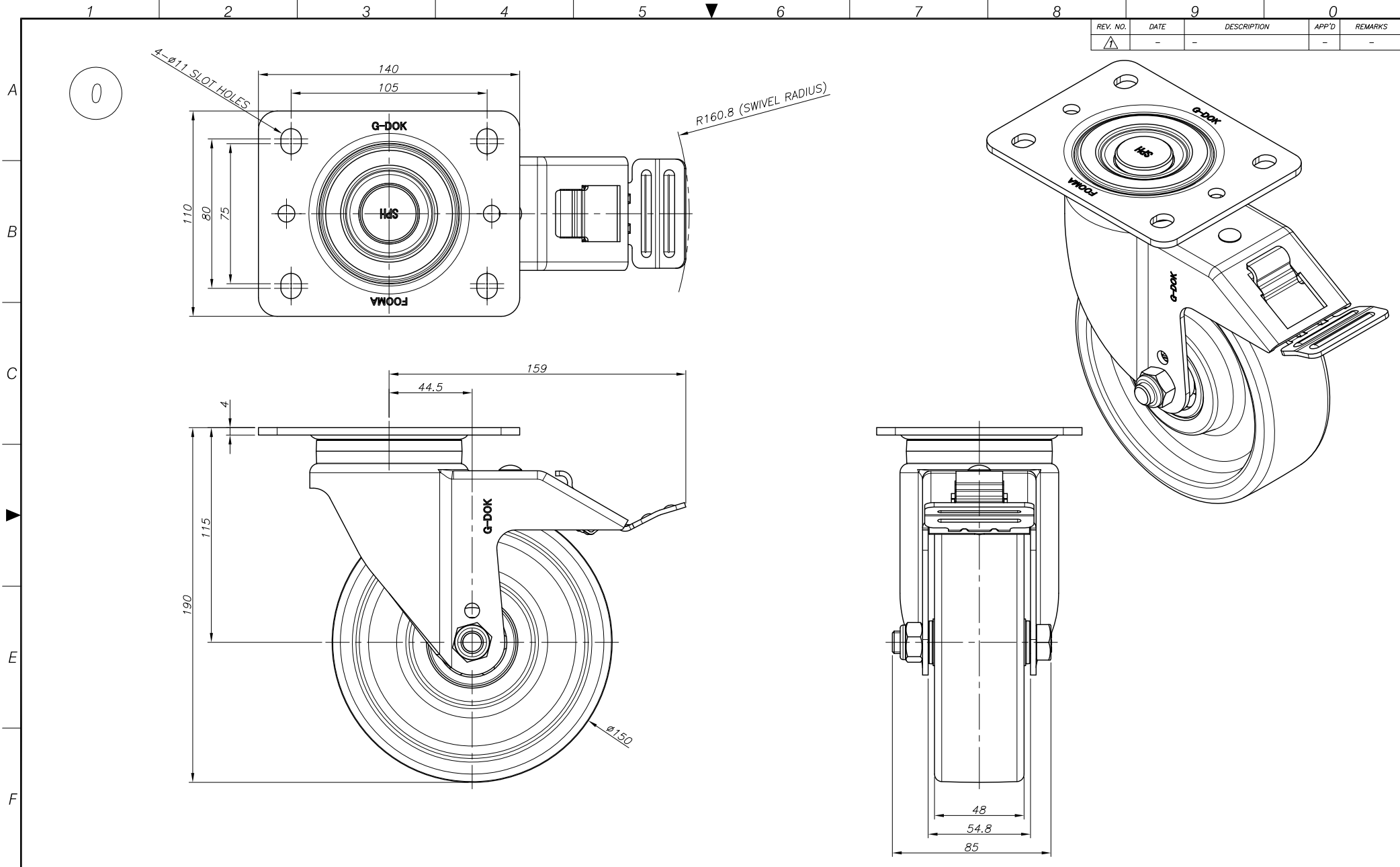

REV. NO.	DATE	DESCRIPTION	APP'D	REMARKS
-	-	-	-	-

NOTE
 1) MATERIAL : STAINLESS

PROCESS	GENERAL TOLERANCE															
MATERIAL	MACHINING WORKING				DIE CASTINGS				INJECTION MOLDING				PRESS WORKING			
	FINISH	PRECISION	SHAPE	ANGLE	FINISH	PRECISION	SHAPE	ANGLE	FINISH	PRECISION	SHAPE	ANGLE	FINISH	PRECISION	SHAPE	ANGLE
APPROVED BY	O.C.K				J.Y.H				K.S.J							
CHECKED BY																
DRAWN BY																

NO.	DESCRIPTION	UNIT	Q'TY	MATERIAL	WEIGHT	SPECIFICATION	REMARKS
--	--	-	-	-	-	-	-

SERIES NAME		SPH-SERIES		DATE	2026.05.18	GSN NO.	4H333-211111
PRODUCT NAME		SPH-150-BSF-NYD-PEU		SCALE	1/2	DWG. NO.	4H333-211111
PART NAME		ASSEMBLY		WEIGHT	--	REVISION	SIZE A3
		GENERAL TOLERANCE		B		ANGLE	

FOOT MASTER G-DOK IND.

REV. NO.	DATE	DESCRIPTION	APP'D	REMARKS
1	-	-	-	-

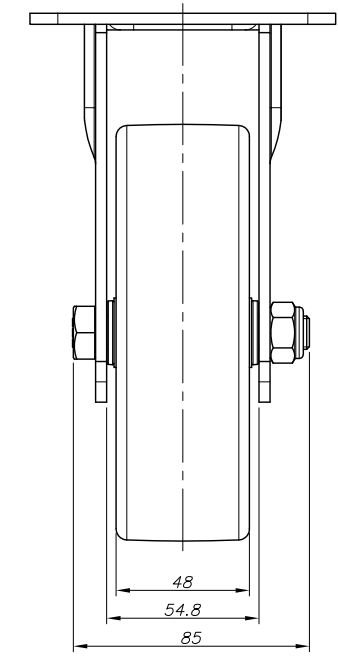
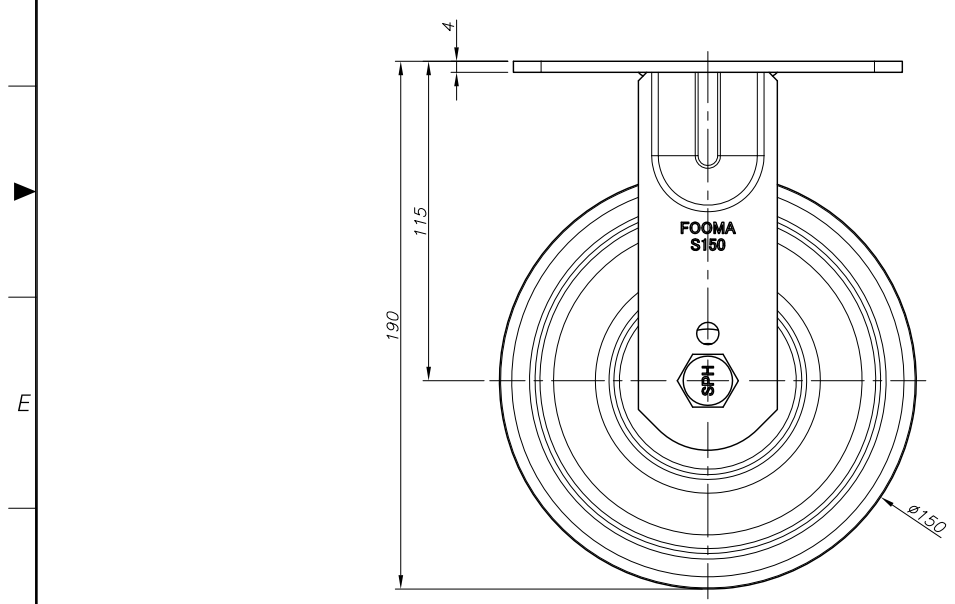
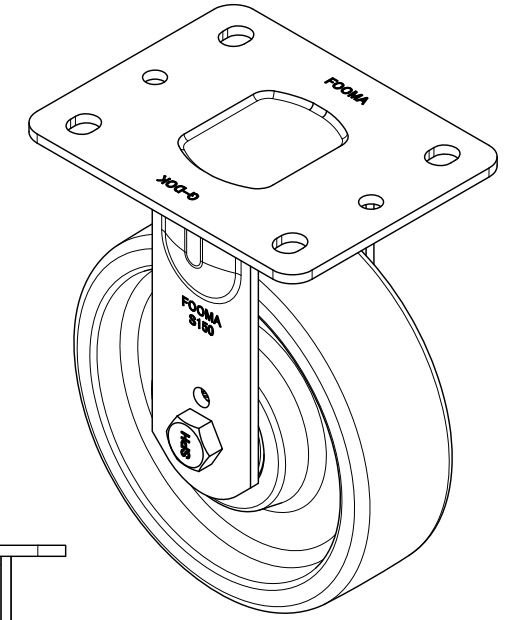
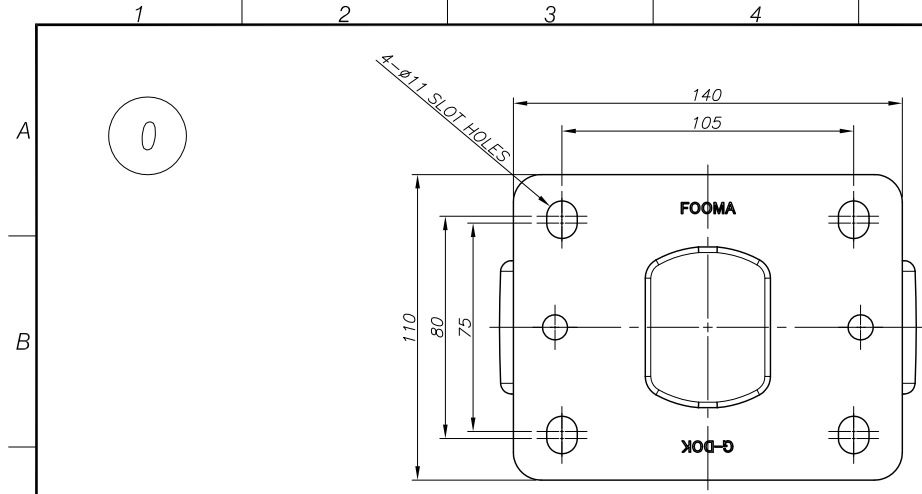

NOTE
 1) MATERIAL : STAINLESS

NO.	DESCRIPTION	UNIT	Q'TY	MATERIAL	WEIGHT	SPECIFICATION	REMARKS
--	--	-	-	-	-	-	-

PROCESS	MATERIAL	APPROVED BY	CHECKED BY	DRAWN BY	PRODUCT GENERAL TOLERANCE																														
--	--	O.C.K	J.Y.H	K.S.J	<table border="1"> <thead> <tr> <th>CHAMFER</th> <th>0.5</th> <th>ROUND</th> <th>0.5</th> <th>UNIT</th> <th>mm</th> </tr> </thead> <tbody> <tr> <td>MACHINING WORKING</td> <td></td> <td></td> <td></td> <td></td> <td></td> </tr> <tr> <td>DIE CASTINGS</td> <td></td> <td></td> <td></td> <td></td> <td></td> </tr> <tr> <td>INJECTION MOLDING</td> <td></td> <td></td> <td></td> <td></td> <td></td> </tr> <tr> <td>PRESS WORKING</td> <td></td> <td></td> <td></td> <td></td> <td></td> </tr> </tbody> </table>	CHAMFER	0.5	ROUND	0.5	UNIT	mm	MACHINING WORKING						DIE CASTINGS						INJECTION MOLDING						PRESS WORKING					
CHAMFER	0.5	ROUND	0.5	UNIT	mm																														
MACHINING WORKING																																			
DIE CASTINGS																																			
INJECTION MOLDING																																			
PRESS WORKING																																			

FOOT MASTER®		FOOMA®		G-DOK IND.	
SERIES NAME	SPH-SERIES	DATE	2026.05.18	GSN NO.	4H323-211111
PRODUCT NAME	SPH-150-ARF-NYD-PEU	SCALE	1/2	DWG. NO.	4H323-211111
PART NAME	ASSEMBLY	WEIGHT	--	REVISION	SIZE A3
GENERAL TOLERANCE		B	ANGLE		

FOOT MASTER G-DOK IND.