

| REV. NO. | DATE | DESCRIPTION | APP'D | REMARKS |
|----------|------|-------------|-------|---------|
| ▲        | -    | -           | -     | -       |

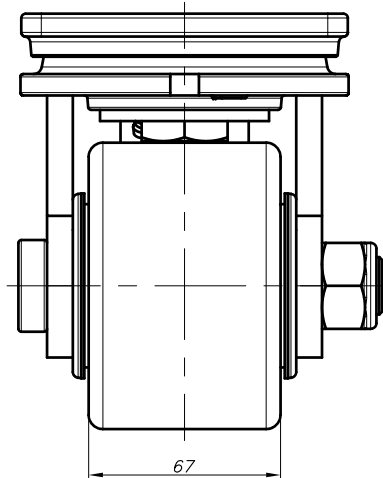
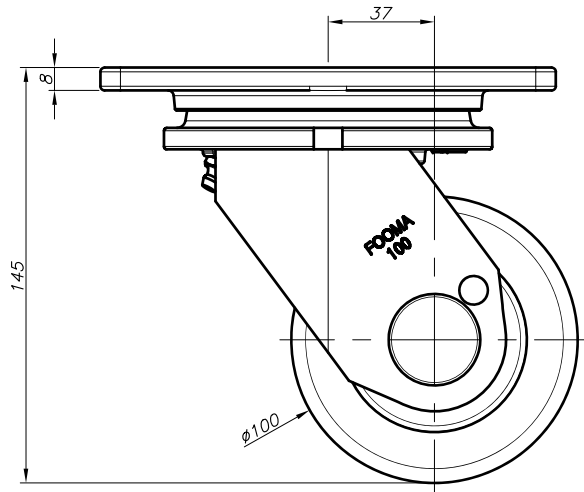
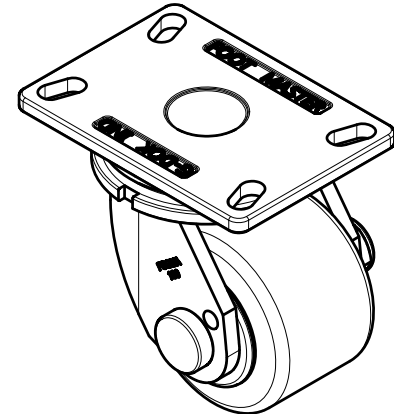
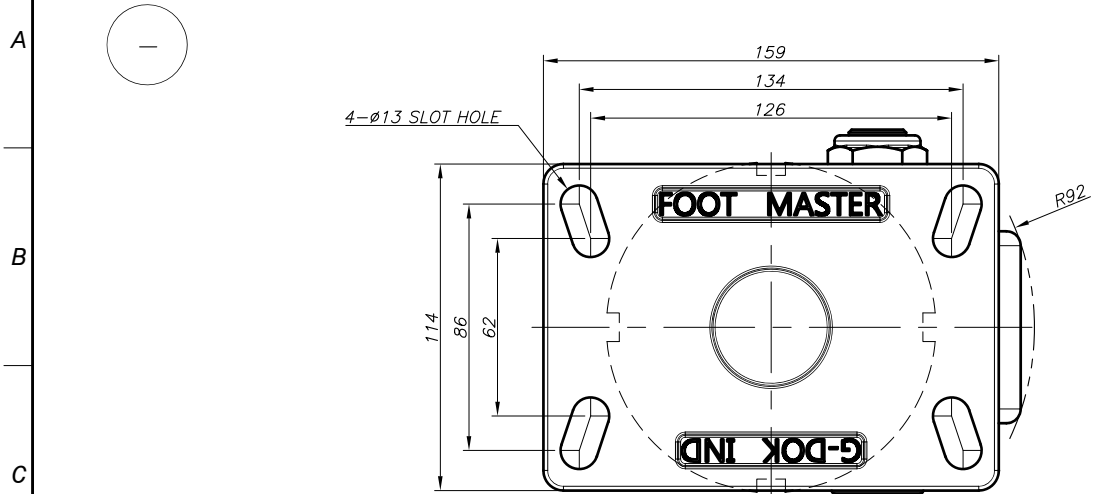

NOTE  
 ※1) --

| NO. | DESCRIPTION | UNIT | Q'TY | MATERIAL | WEIGHT | SPECIFICATION | REMARKS |
|-----|-------------|------|------|----------|--------|---------------|---------|
| --  | --          | --   | --   | --       | --     | --            | --      |

| PROCESS |     | MATERIAL |     | APPROVED BY |       | CHECKED BY |  | DRAWN BY |  |
|---------|-----|----------|-----|-------------|-------|------------|--|----------|--|
| ---     | --- | ---      | --- | O.C.K       | J.Y.H | S.D.W      |  |          |  |

| GENERAL TOLERANCE |               |             |            |               |             |            |                   |             |            |               |             |
|-------------------|---------------|-------------|------------|---------------|-------------|------------|-------------------|-------------|------------|---------------|-------------|
| MACHINING WORKING |               |             |            |               | DIE CASTING |            | INJECTION MOLDING |             |            | PRESS WORKING |             |
| FINISH            | PRECISION (μ) | GENERAL (μ) | FINISH (μ) | PRECISION (μ) | GENERAL (μ) | FINISH (μ) | PRECISION (μ)     | GENERAL (μ) | FINISH (μ) | PRECISION (μ) | GENERAL (μ) |
| 0.5 - 6           | ±0.05         | ±0.1        | 1-10       | ±0.1          | ±0.2        | 1-10       | ±0.1              | ±0.2        | 1-10       | ±0.1          | ±0.2        |
| 6 - 30            | ±0.1          | ±0.2        | 10-30      | ±0.1          | ±0.2        | 10-30      | ±0.1              | ±0.2        | 10-30      | ±0.1          | ±0.2        |
| 30 - 120          | ±0.15         | ±0.3        | 30-120     | ±0.15         | ±0.3        | 30-120     | ±0.15             | ±0.3        | 30-120     | ±0.15         | ±0.3        |
| 120 - 400         | ±0.2          | ±0.5        | 120-400    | ±0.2          | ±0.5        | 120-400    | ±0.2              | ±0.5        | 120-400    | ±0.2          | ±0.5        |
| 400 - 1000        | ±0.3          | ±0.8        | 400-1000   | ±0.3          | ±0.8        | 400-1000   | ±0.3              | ±0.8        | 400-1000   | ±0.3          | ±0.8        |

| FOOT MASTER® |                | FOOMA®            |            | G-DOK IND. |   |
|--------------|----------------|-------------------|------------|------------|---|
| SERIES NAME  | GF-SERIES      | DATE              | 2023.08.21 | GSN NO.    | - |
| PRODUCT NAME | GF-100-ASF-MCD | SCALE             | N/S        | DWG. NO.   | - |
| PART NAME    | ASSEMBLY       | WEIGHT            | --         | REVISION   |   |
|              |                | GENERAL TOLERANCE | --         | ANGLE      | ▲ |

FOOT MASTER G-DOK IND.

| REV. NO. | DATE | DESCRIPTION | APP'D | REMARKS |
|----------|------|-------------|-------|---------|
| 1        | -    | -           | -     | -       |

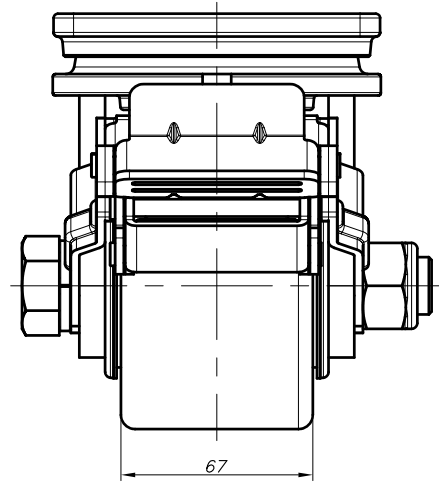
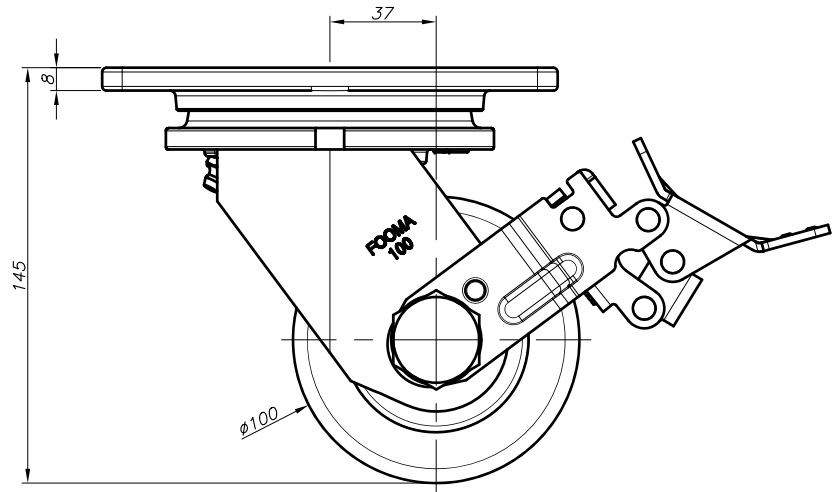
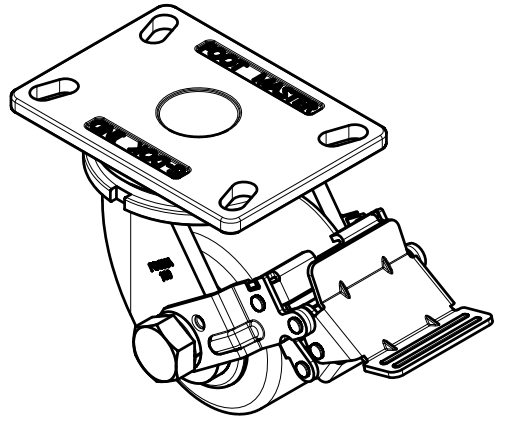
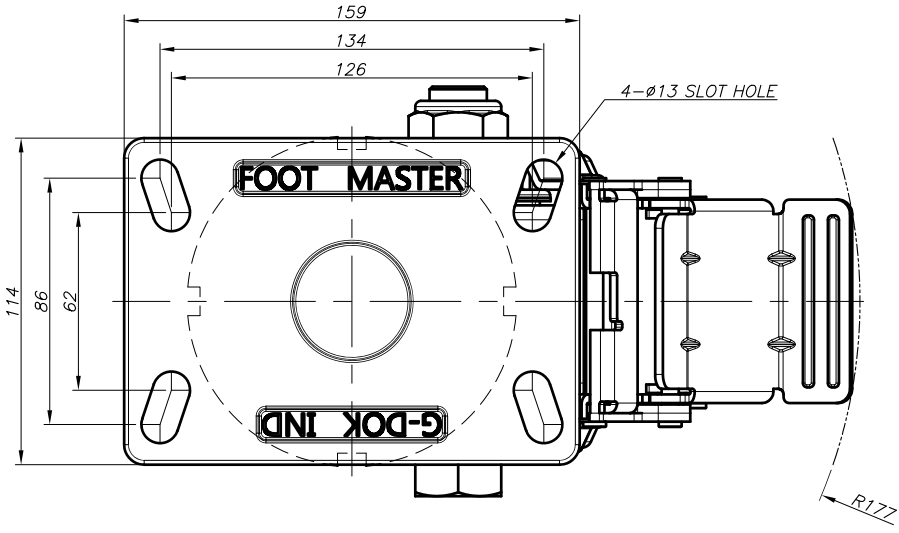
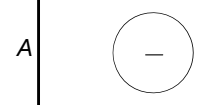

**NOTE**

※1) --

| NO. | DESCRIPTION | UNIT | Q'TY | MATERIAL | WEIGHT | SPECIFICATION | REMARKS |
|-----|-------------|------|------|----------|--------|---------------|---------|
| --  | --          | --   | --   | --       | --     | --            | --      |

|             |            |                          |          |             |      |                   |       |               |          |       |      |
|-------------|------------|--------------------------|----------|-------------|------|-------------------|-------|---------------|----------|-------|------|
| PROCESS     | ---        | <b>GENERAL TOLERANCE</b> |          |             |      |                   |       |               |          |       |      |
| MATERIAL    | ---        | MACHINING WORKING        |          | DIE CASTING |      | INJECTION MOLDING |       | PRESS WORKING |          |       |      |
| APPROVED BY | CHECKED BY | DRAWN BY                 | NAME     | PRESN       | GENR | NAME              | PRESN | GENR          | NAME     | PRESN | GENR |
| O.C.K       | J.Y.H      | S.D.W                    | 0.5-6    | ±0.05       | ±0.1 | 1-6               | ±0.05 | ±0.1          | 1-6      | ±0.05 | ±0.1 |
|             |            |                          | 6-30     | ±0.1        | ±0.2 | 3-30              | ±0.05 | ±0.1          | 3-30     | ±0.05 | ±0.1 |
|             |            |                          | 30-120   | ±0.15       | ±0.3 | 30-120            | ±0.05 | ±0.1          | 30-120   | ±0.05 | ±0.1 |
|             |            |                          | 120-400  | ±0.2        | ±0.5 | 120-400           | ±0.05 | ±0.1          | 120-400  | ±0.05 | ±0.1 |
|             |            |                          | 400-1000 | ±0.3        | ±0.8 | 400-1000          | ±0.05 | ±0.1          | 400-1000 | ±0.05 | ±0.1 |

|                     |                |                   |            |                   |   |
|---------------------|----------------|-------------------|------------|-------------------|---|
| <b>FOOT MASTER®</b> |                | <b>FOOMA®</b>     |            | <b>G-DOK IND.</b> |   |
| SERIES NAME         | GF-SERIES      | DATE              | 2023.08.21 | GSN NO.           | - |
| PRODUCT NAME        | GF-100-BSF-MCD | SCALE             | N/S        | DWG. NO.          | - |
| PART NAME           | ASSEMBLY       | WEIGHT            | --         | REVISION          | - |
|                     |                | GENERAL TOLERANCE | --         | ANGLE             | △ |

FOOT MASTER G-DOK IND.

| REV. NO. | DATE | DESCRIPTION | APP'D | REMARKS |
|----------|------|-------------|-------|---------|
| ▲        | -    | -           | -     | -       |

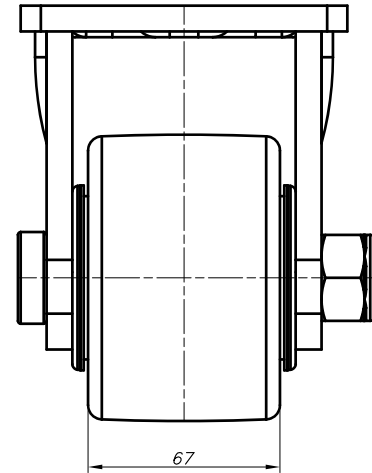
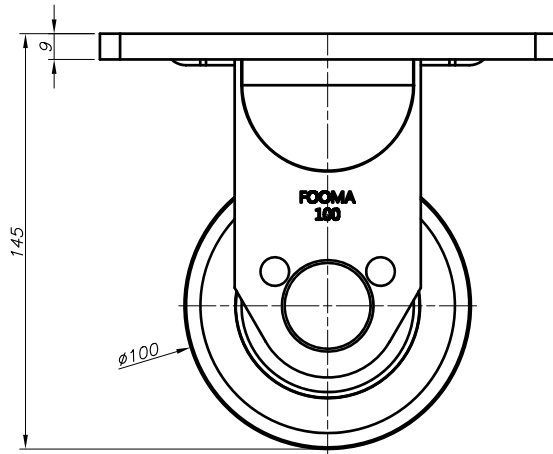
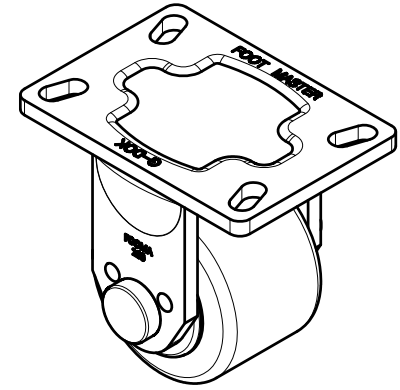
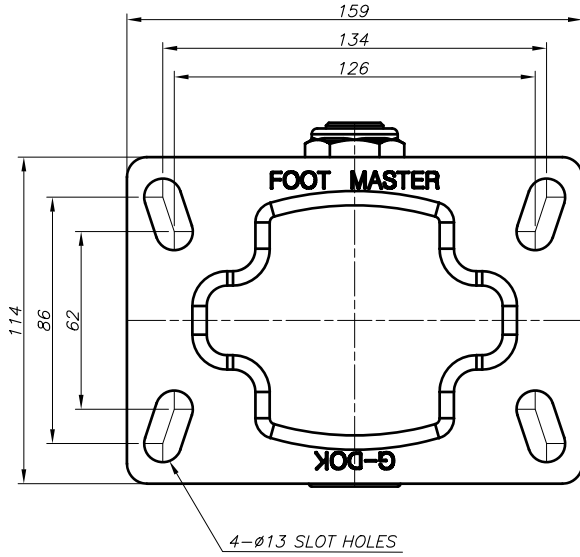

NOTE  
※ 1) --

| PROCESS     |            |          | GENERAL TOLERANCE |               |             |            |               |             |                   |               |             |            |               |             |
|-------------|------------|----------|-------------------|---------------|-------------|------------|---------------|-------------|-------------------|---------------|-------------|------------|---------------|-------------|
| MATERIAL    |            |          | MACHINING WORKING |               |             |            | DIE CASTING   |             | INJECTION MOLDING |               |             |            | PRESS WORKING |             |
| APPROVED BY | CHECKED BY | DRAWN BY | FINISH            | PRECISION (μ) | GENERAL (μ) | FINISH (μ) | PRECISION (μ) | GENERAL (μ) | FINISH (μ)        | PRECISION (μ) | GENERAL (μ) | FINISH (μ) | PRECISION (μ) | GENERAL (μ) |
| O.C.K       | J.Y.H      | S.D.W    | 0.5-6             | ±0.05         | ±0.1        | 1-10       | ±0.1          | ±0.2        | 1-10              | ±0.1          | ±0.2        | 1-10       | ±0.1          | ±0.2        |
|             |            |          | 6-30              | ±0.1          | ±0.2        | 1-10       | ±0.1          | ±0.2        | 1-10              | ±0.1          | ±0.2        | 1-10       | ±0.1          | ±0.2        |
|             |            |          | 30-120            | ±0.15         | ±0.3        | 1-10       | ±0.1          | ±0.2        | 1-10              | ±0.1          | ±0.2        | 1-10       | ±0.1          | ±0.2        |
|             |            |          | 120-400           | ±0.2          | ±0.5        | 1-10       | ±0.1          | ±0.2        | 1-10              | ±0.1          | ±0.2        | 1-10       | ±0.1          | ±0.2        |
|             |            |          | 400-1000          | ±0.3          | ±0.8        | 1-10       | ±0.1          | ±0.2        | 1-10              | ±0.1          | ±0.2        | 1-10       | ±0.1          | ±0.2        |

| FOOT MASTER® |                | FOOMA®            |            | G-DOK IND. |         |
|--------------|----------------|-------------------|------------|------------|---------|
| SERIES NAME  | GF-SERIES      | DATE              | 2023.08.21 | GSN NO.    | -       |
| PRODUCT NAME | GF-100-ARF-MCD | SCALE             | N/S        | DWG. NO.   | -       |
| PART NAME    | ASSEMBLY       | WEIGHT            | --         | REVISION   | SIZE A3 |
|              |                | GENERAL TOLERANCE | --         | ANGLE      | ▲       |

FOOT MASTER G-DOK IND.

| REV. NO. | DATE | DESCRIPTION | APP'D | REMARKS |
|----------|------|-------------|-------|---------|
| ▲        | -    | -           | -     | -       |

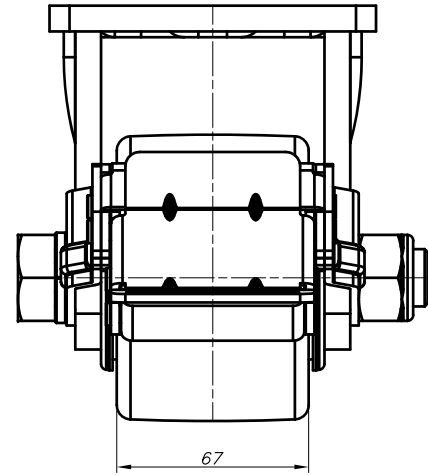
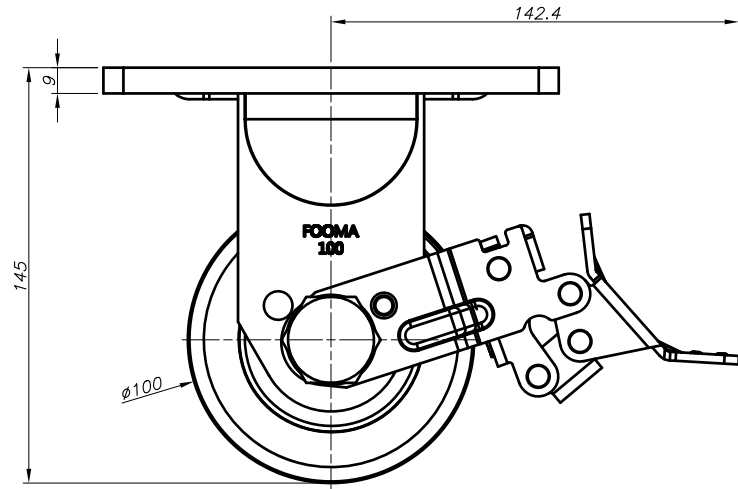
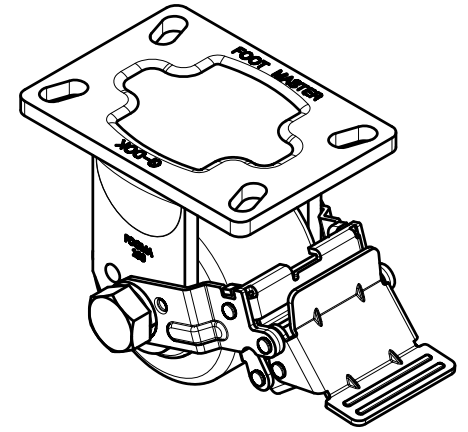
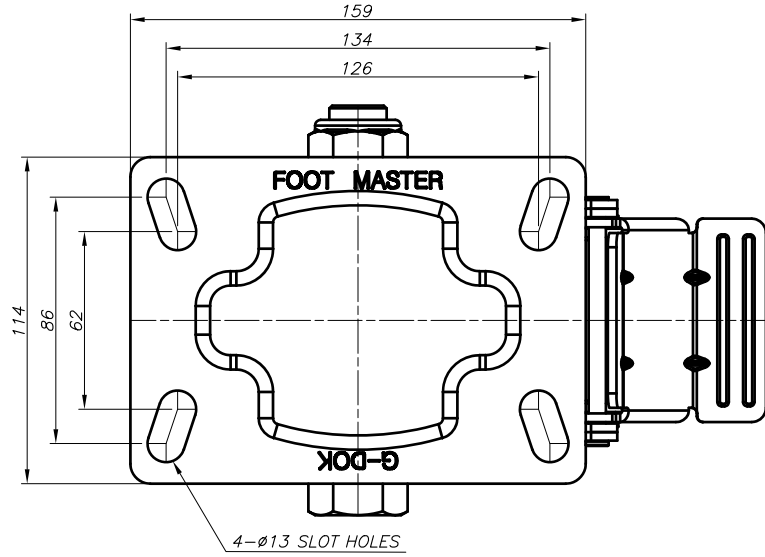

NOTE

※1) --

| NO. | DESCRIPTION | UNIT | Q'TY | MATERIAL | WEIGHT | SPECIFICATION | REMARKS |
|-----|-------------|------|------|----------|--------|---------------|---------|
| --  | --          | --   | --   | --       | --     | --            | --      |

| PROCESS     |            | ---      |  |
|-------------|------------|----------|--|
| MATERIAL    |            | ---      |  |
| APPROVED BY | CHECKED BY | DRAWN BY |  |
| O.C.K       | J.Y.H      | S.D.W    |  |

| GENERAL TOLERANCE |         |         |             |         |       | CHAMFER           | 0.5     | ROUND   | 0.5           | UNIT  | mm      |
|-------------------|---------|---------|-------------|---------|-------|-------------------|---------|---------|---------------|-------|---------|
| MACHINING WORKING |         |         | DIE CASTING |         |       | INJECTION MOLDING |         |         | PRESS WORKING |       |         |
| MINUS             | PRESION | GENERAL | MINUS       | CHAMFER | ROUND | MINUS             | PRESION | CHAMFER | ROUND         | MINUS | PRESION |
| 0.5 - 6           | ±0.05   | ±0.1    | 0.5 - 6     | 0.5     | 0.5   | 0.5 - 6           | 0.5     | 0.5     | 0.5           | 0.5   | 0.5     |
| 6 - 30            | ±0.1    | ±0.2    | 30 - 120    | ±0.15   | ±0.3  | 30 - 120          | ±0.15   | ±0.3    | 30 - 120      | ±0.15 | ±0.3    |
| 120 - 400         | ±0.2    | ±0.5    | 400 - 1000  | ±0.3    | ±0.8  | 120 - 400         | ±0.2    | ±0.5    | 400 - 1000    | ±0.3  | ±0.8    |

| PRODUCT GENERAL TOLERANCE |                      |                  |                  |                 |         |
|---------------------------|----------------------|------------------|------------------|-----------------|---------|
| CASTER HEIGHT             | WHEEL OUTER DIAMETER | WHEEL HUB WIDTH  | PRESION          | GENERAL         | PRESION |
| ±0.5K<br>(0.015mm)        | ±1K<br>(0.025mm)     | ±1K<br>(0.025mm) | -1K<br>(0.025mm) | -2K<br>(0.05mm) |         |

| FOOT MASTER® |                | FOOMA®            |            | G-DOK IND. |   |
|--------------|----------------|-------------------|------------|------------|---|
| SERIES NAME  | GF-SERIES      | DATE              | 2023.08.21 | GSN NO.    | - |
| PRODUCT NAME | GF-100-BRF-MCD | SCALE             | N/S        | DWG. NO.   | - |
| PART NAME    | ASSEMBLY       | WEIGHT            | --         | REVISION   |   |
|              |                | GENERAL TOLERANCE | --         | ANGLE      | ▲ |