

| REV. NO. | DATE | DESCRIPTION | APP'D | REMARKS |
|----------|------|-------------|-------|---------|
| ▲        | -    | -           | -     | -       |

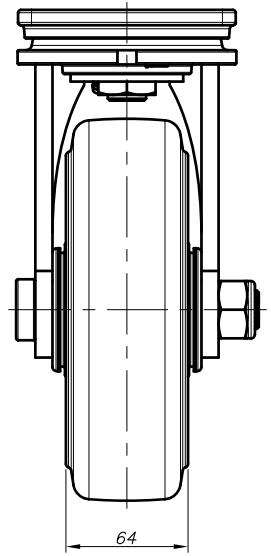
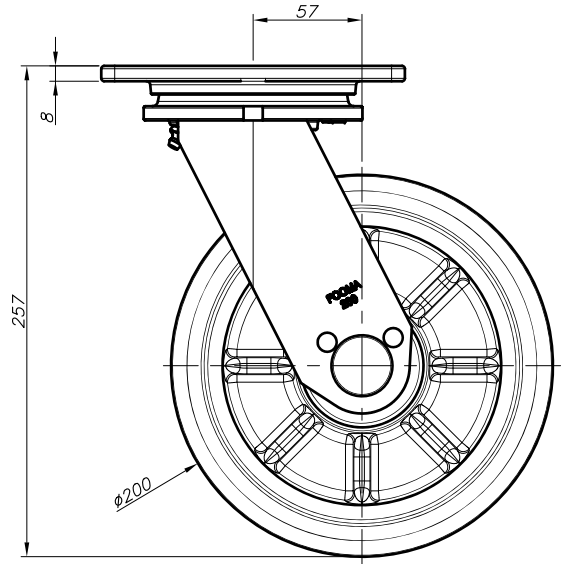
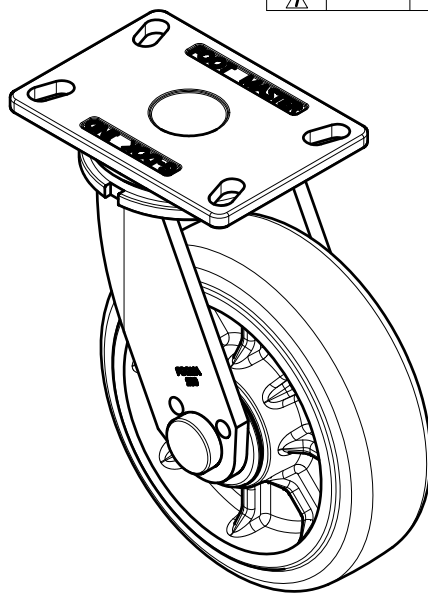
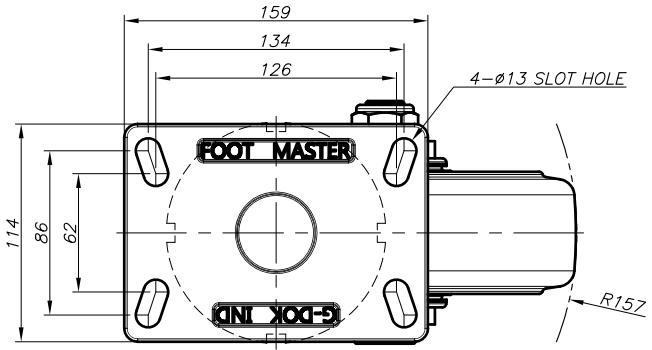

NOTE

※ 1) --

| NO. | DESCRIPTION | UNIT | Q'TY | MATERIAL | WEIGHT | SPECIFICATION | REMARKS |
|-----|-------------|------|------|----------|--------|---------------|---------|
| --  | --          | --   | --   | --       | --     | --            | --      |

| PROCESS   |         | MATERIAL  |         | APPROVED BY |         | CHECKED BY |         | DRAWN BY  |         | PRODUCT GENERAL TOLERANCE |                      | GENERAL TOLERANCE |                 | MACHINING WORKING |               | DIE CASTING   |               | INJECTION MOLDING |               | PRESS WORKING |               |               |      |
|-----------|---------|-----------|---------|-------------|---------|------------|---------|-----------|---------|---------------------------|----------------------|-------------------|-----------------|-------------------|---------------|---------------|---------------|-------------------|---------------|---------------|---------------|---------------|------|
| PROCESS   | ---     | MATERIAL  | ---     | APPROVED BY | O.C.K   | CHECKED BY | J.Y.H   | DRAWN BY  | S.D.W   | CASTER HEIGHT             | WHEEL OUTER DIAMETER | WHEEL HUB WIDTH   | WHEEL RIM WIDTH | WHEEL CENTER DIA  | WHEEL HUB DIA | WHEEL RIM DIA | WHEEL HUB DIA | WHEEL RIM DIA     | WHEEL HUB DIA | WHEEL RIM DIA | WHEEL HUB DIA | WHEEL RIM DIA |      |
| PRECISION | GENERAL | PRECISION | GENERAL | PRECISION   | GENERAL | PRECISION  | GENERAL | PRECISION | GENERAL | 0.5 - 6                   | ±0.05                | ±0.1              | ±0.1            | ±0.1              | ±0.1          | ±0.1          | ±0.1          | ±0.1              | ±0.1          | ±0.1          | ±0.1          | ±0.1          | ±0.1 |
| 0.5 - 30  | ±0.1    | ±0.2      | ±0.2    | ±0.2        | ±0.2    | ±0.2       | ±0.2    | ±0.2      | ±0.2    | 30 - 120                  | ±0.15                | ±0.3              | ±0.3            | ±0.3              | ±0.3          | ±0.3          | ±0.3          | ±0.3              | ±0.3          | ±0.3          | ±0.3          | ±0.3          | ±0.3 |
| 120 - 400 | ±0.2    | ±0.5      | ±0.5    | ±0.5        | ±0.5    | ±0.5       | ±0.5    | ±0.5      | ±0.5    | 400 - 1000                | ±0.3                 | ±0.8              | ±0.8            | ±0.8              | ±0.8          | ±0.8          | ±0.8          | ±0.8              | ±0.8          | ±0.8          | ±0.8          | ±0.8          | ±0.8 |

| FOOT MASTER® |                | FOOMA®            |            | G-DOK IND. |         |
|--------------|----------------|-------------------|------------|------------|---------|
| SERIES NAME  | GF-SERIES      | DATE              | 2023.08.21 | GSN NO.    | -       |
| PRODUCT NAME | GF-200-ASF-MUD | SCALE             | N/S        | DWG. NO.   | -       |
| PART NAME    | ASSEMBLY       | WEIGHT            | --         | REVISION   | SIZE A3 |
|              |                | GENERAL TOLERANCE | --         | ANGLE      | ▲       |

FOOT MASTER G-DOK IND.

| REV. NO. | DATE | DESCRIPTION | APP'D | REMARKS |
|----------|------|-------------|-------|---------|
| ▲        | -    | -           | -     | -       |

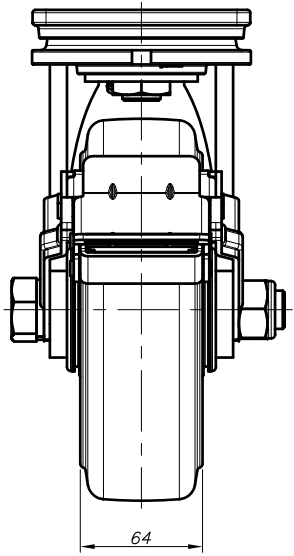
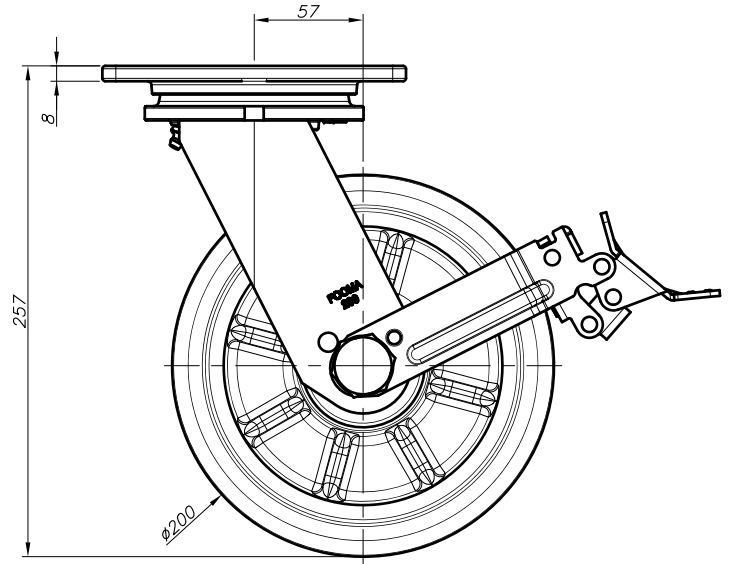
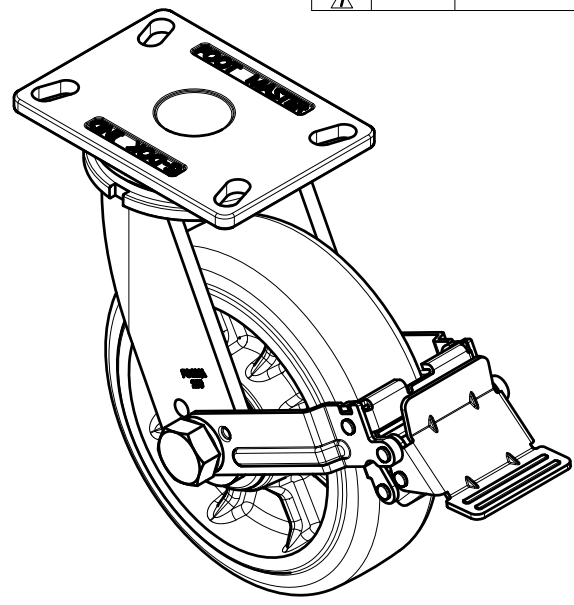
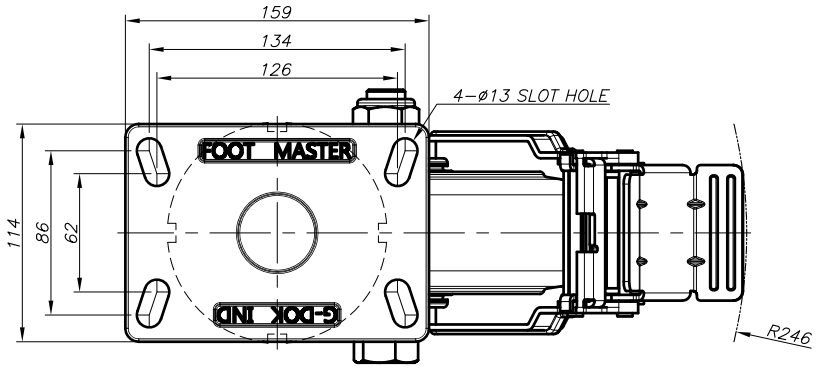

NOTE

※ 1) --

| NO. | DESCRIPTION | UNIT | Q'TY | MATERIAL | WEIGHT | SPECIFICATION | REMARKS |
|-----|-------------|------|------|----------|--------|---------------|---------|
| --  | --          | --   | --   | --       | --     | --            | --      |

| PROCESS |  | MATERIAL |  | APPROVED BY |  | CHECKED BY |  | DRAWN BY |  | GENERAL TOLERANCE |  | CHAMFER     |  | D.S.              |  | ROAD          |  | D.S.      |  | UNIT    |  | mm |  |
|---------|--|----------|--|-------------|--|------------|--|----------|--|-------------------|--|-------------|--|-------------------|--|---------------|--|-----------|--|---------|--|----|--|
| ---     |  | ---      |  | O.C.K       |  | J.Y.H      |  | S.D.W    |  | MACHINING WORKING |  | DIE CASTING |  | INJECTION MOLDING |  | PRESS WORKING |  |           |  |         |  |    |  |
|         |  |          |  |             |  |            |  |          |  | FINISH            |  | PRECISION   |  | GENERAL           |  | FINISH        |  | PRECISION |  | GENERAL |  |    |  |
|         |  |          |  |             |  |            |  |          |  | 0.5 - 6           |  | ±0.05       |  | ±0.1              |  | P-0           |  | A0        |  | A0      |  | F  |  |
|         |  |          |  |             |  |            |  |          |  | 6 - 30            |  | ±0.1        |  | ±0.2              |  | P-0           |  | A0        |  | A0      |  | F  |  |
|         |  |          |  |             |  |            |  |          |  | 30 - 120          |  | ±0.15       |  | ±0.3              |  | P-0           |  | A0        |  | A0      |  | F  |  |
|         |  |          |  |             |  |            |  |          |  | 120 - 400         |  | ±0.2        |  | ±0.5              |  | P-0           |  | A0        |  | A0      |  | F  |  |
|         |  |          |  |             |  |            |  |          |  | 400 - 1000        |  | ±0.3        |  | ±0.8              |  | P-0           |  | A0        |  | A0      |  | F  |  |

| FOOT MASTER® |                | FOOMA®            |            | G-DOK IND. |   |
|--------------|----------------|-------------------|------------|------------|---|
| SERIES NAME  | GF-SERIES      | DATE              | 2023.08.21 | GSN NO.    | - |
| PRODUCT NAME | GF-200-BSF-MUD | SCALE             | N/S        | DWG. NO.   | - |
| PART NAME    | ASSEMBLY       | WEIGHT            | --         | REVISION   |   |
|              |                | GENERAL TOLERANCE | --         | ANGLE      | ▲ |

| REV. NO. | DATE | DESCRIPTION | APP'D | REMARKS |
|----------|------|-------------|-------|---------|
| ▲        | -    | -           | -     | -       |

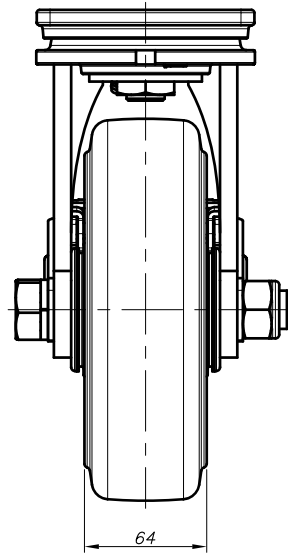
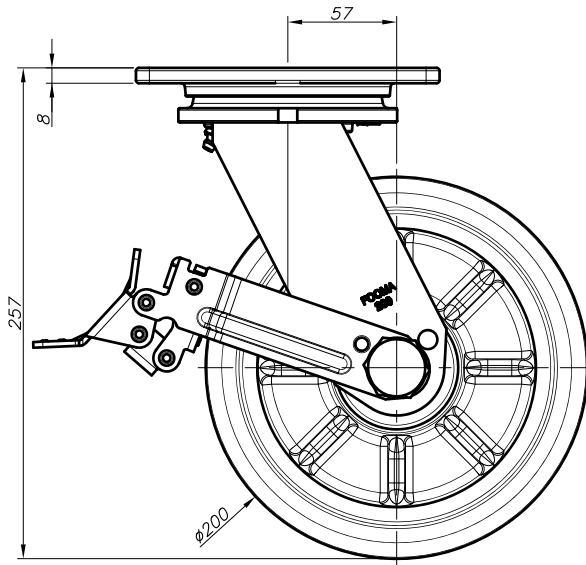
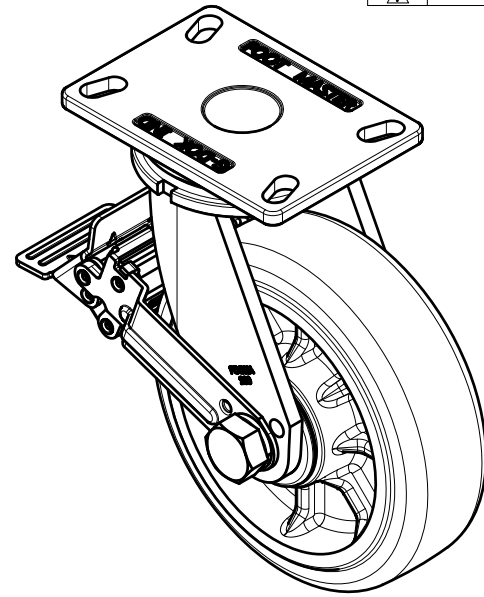
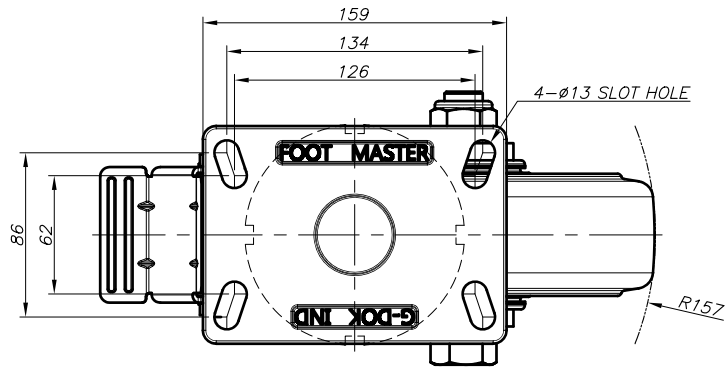

NOTE

※1) --

| NO. | DESCRIPTION | UNIT | Q'TY | MATERIAL | WEIGHT | SPECIFICATION | REMARKS |
|-----|-------------|------|------|----------|--------|---------------|---------|
| --  | --          | --   | --   | --       | --     | --            | --      |

| PROCESS |  | MATERIAL |  | APPROVED BY |  | CHECKED BY |  | DRAWN BY |  |
|---------|--|----------|--|-------------|--|------------|--|----------|--|
| ---     |  | ---      |  | O.C.K       |  | J.Y.H      |  | S.D.W    |  |

| GENERAL TOLERANCE |               |             |            |               |             |            |                   |             |            |               |             |
|-------------------|---------------|-------------|------------|---------------|-------------|------------|-------------------|-------------|------------|---------------|-------------|
| MACHINING WORKING |               |             |            |               | DIE CASTING |            | INJECTION MOLDING |             |            | PRESS WORKING |             |
| FINISH            | PRECISION (μ) | GENERAL (μ) | FINISH (μ) | PRECISION (μ) | GENERAL (μ) | FINISH (μ) | PRECISION (μ)     | GENERAL (μ) | FINISH (μ) | PRECISION (μ) | GENERAL (μ) |
| 0.5 - 6           | ±0.05         | ±0.1        | 1-#        | ±0.1          | ±0.2        | 1-#        | ±0.1              | ±0.2        | 1-#        | ±0.1          | ±0.2        |
| 6 - 30            | ±0.1          | ±0.2        | 2-#        | ±0.1          | ±0.3        | 2-#        | ±0.1              | ±0.3        | 2-#        | ±0.1          | ±0.3        |
| 30 - 120          | ±0.15         | ±0.3        | 3-#        | ±0.1          | ±0.4        | 3-#        | ±0.1              | ±0.4        | 3-#        | ±0.1          | ±0.4        |
| 120 - 400         | ±0.2          | ±0.5        | 4-#        | ±0.1          | ±0.6        | 4-#        | ±0.1              | ±0.6        | 4-#        | ±0.1          | ±0.6        |
| 400 - 1000        | ±0.3          | ±0.8        | 5-#        | ±0.1          | ±1.0        | 5-#        | ±0.1              | ±1.0        | 5-#        | ±0.1          | ±1.0        |

| PRODUCT GENERAL TOLERANCE |             |                      |             |                 |             |
|---------------------------|-------------|----------------------|-------------|-----------------|-------------|
| CASTER HEIGHT             |             | WHEEL OUTER DIAMETER |             | WHEEL HUB WIDTH |             |
| PRECISION                 | GENERAL     | PRECISION            | GENERAL     | PRECISION       | GENERAL     |
| ±0.5K (0.05mm)            | ±1K (0.1mm) | ±0.5K (0.05mm)       | ±1K (0.1mm) | -1K (0.1mm)     | -2K (0.2mm) |

| SERIES NAME        |  | DATE       |  | GSN NO.  |  |
|--------------------|--|------------|--|----------|--|
| GF-SERIES          |  | 2023.08.21 |  | -        |  |
| PRODUCT NAME       |  | SCALE      |  | DWG. NO. |  |
| GF-200-BSF-MUD-FRN |  | N/S        |  | -        |  |
| PART NAME          |  | WEIGHT     |  | REVISION |  |
| ASSEMBLY           |  | --         |  | -        |  |

| FOOT MASTER®      |  | FOOMA® |  | G-DOK IND. |  |
|-------------------|--|--------|--|------------|--|
| GENERAL TOLERANCE |  | --     |  | ANGLE      |  |

FOOT MASTER G-DOK IND.

| REV. NO. | DATE | DESCRIPTION | APP'D | REMARKS |
|----------|------|-------------|-------|---------|
| ▲        | -    | -           | -     | -       |

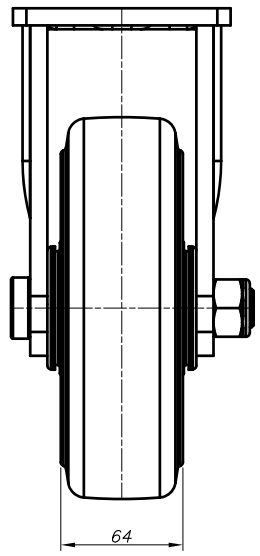
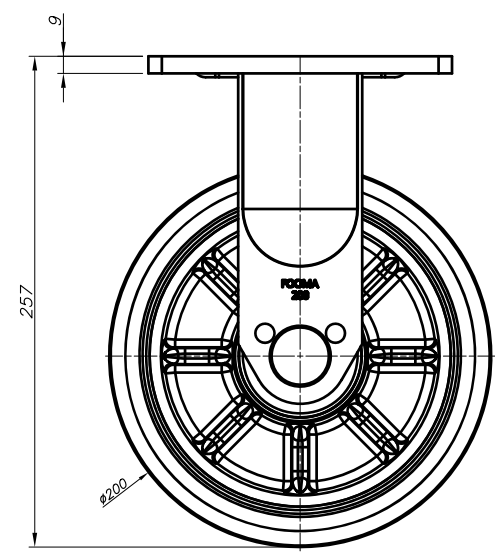
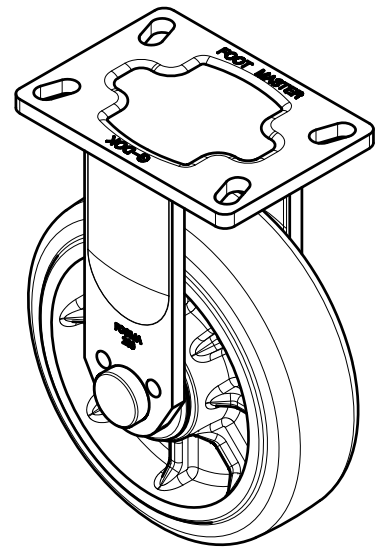
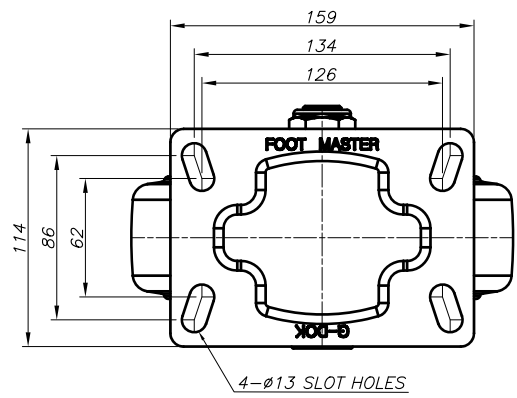

**NOTE**

※ 1) --

| NO. | DESCRIPTION | UNIT | Q'TY | MATERIAL | WEIGHT | SPECIFICATION | REMARKS |
|-----|-------------|------|------|----------|--------|---------------|---------|
| --  | --          | --   | --   | --       | --     | --            | --      |

| PROCESS     |            | MATERIAL |               | APPROVED BY          |                 | CHECKED BY |         | DRAWN BY  |         | PRODUCT GENERAL TOLERANCE |         | GENERAL TOLERANCE |         | MACHINING WORKING |         | DIE CASTING |         | INJECTION MOLDING |         | PRESS WORKING |         |
|-------------|------------|----------|---------------|----------------------|-----------------|------------|---------|-----------|---------|---------------------------|---------|-------------------|---------|-------------------|---------|-------------|---------|-------------------|---------|---------------|---------|
| APPROVED BY | CHECKED BY | DRAWN BY | CASTER HEIGHT | WHEEL OUTER DIAMETER | WHEEL HUB WIDTH | PRECISION  | GENERAL | PRECISION | GENERAL | PRECISION                 | GENERAL | PRECISION         | GENERAL | PRECISION         | GENERAL | PRECISION   | GENERAL | PRECISION         | GENERAL | PRECISION     | GENERAL |
| O.C.K       | J.Y.H      | S.D.W    | 6-30          | ±0.1                 | ±0.2            | ±0.15      | ±0.3    | ±0.1      | ±0.2    | ±0.1                      | ±0.2    | ±0.1              | ±0.2    | ±0.1              | ±0.2    | ±0.1        | ±0.2    | ±0.1              | ±0.2    | ±0.1          | ±0.2    |
|             |            |          | 30-120        | ±0.1                 | ±0.2            | ±0.1       | ±0.2    | ±0.1      | ±0.2    | ±0.1                      | ±0.2    | ±0.1              | ±0.2    | ±0.1              | ±0.2    | ±0.1        | ±0.2    | ±0.1              | ±0.2    | ±0.1          | ±0.2    |
|             |            |          | 120-400       | ±0.1                 | ±0.2            | ±0.1       | ±0.2    | ±0.1      | ±0.2    | ±0.1                      | ±0.2    | ±0.1              | ±0.2    | ±0.1              | ±0.2    | ±0.1        | ±0.2    | ±0.1              | ±0.2    | ±0.1          | ±0.2    |
|             |            |          | 400-1000      | ±0.1                 | ±0.2            | ±0.1       | ±0.2    | ±0.1      | ±0.2    | ±0.1                      | ±0.2    | ±0.1              | ±0.2    | ±0.1              | ±0.2    | ±0.1        | ±0.2    | ±0.1              | ±0.2    | ±0.1          | ±0.2    |

| SERIES NAME  |        | DATE           |            | GSN NO.  |   |
|--------------|--------|----------------|------------|----------|---|
| PRODUCT NAME |        | SCALE          |            | DWG. NO. |   |
| PART NAME    |        | WEIGHT         |            | REVISION |   |
| FOOT MASTER® | FOOMA® | GF-SERIES      | 2023.08.21 | -        | - |
| GF-SERIES    | N/S    | GF-200-ARF-MUD | --         | -        | - |
| ASSEMBLY     | --     |                |            |          |   |

FOOT MASTER G-DOK IND.

| REV. NO. | DATE | DESCRIPTION | APP'D | REMARKS |
|----------|------|-------------|-------|---------|
| ▲        | -    | -           | -     | -       |

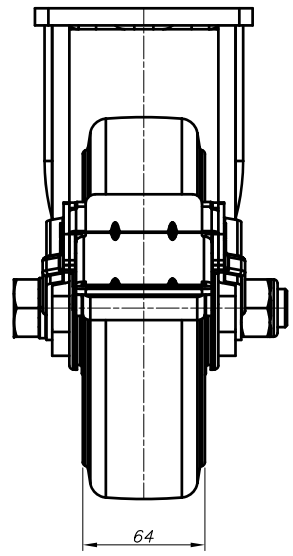
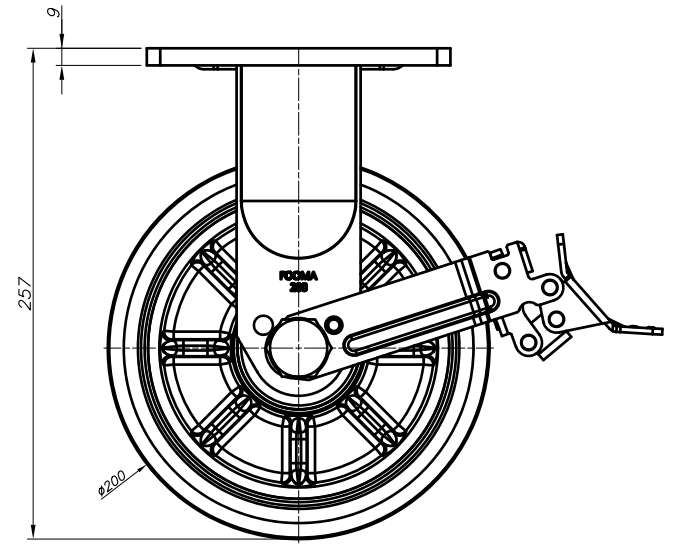
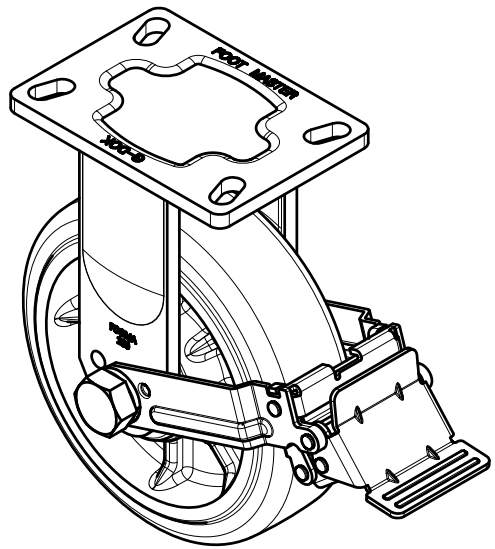
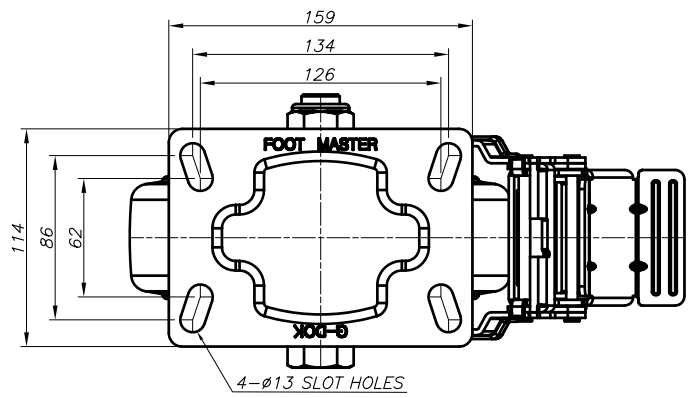

NOTE

※ 1) --

| NO. | DESCRIPTION | UNIT | Q'TY | MATERIAL | WEIGHT | SPECIFICATION | REMARKS |
|-----|-------------|------|------|----------|--------|---------------|---------|
| --  | --          | --   | --   | --       | --     | --            | --      |

| PROCESS     |            |          | GENERAL TOLERANCE |         |        |        |             |           |           |           |                   |           |           |           |               |           |           |  |
|-------------|------------|----------|-------------------|---------|--------|--------|-------------|-----------|-----------|-----------|-------------------|-----------|-----------|-----------|---------------|-----------|-----------|--|
| MATERIAL    |            |          | MACHINING WORKING |         |        |        | DIE CASTING |           |           |           | INJECTION MOLDING |           |           |           | PRESS WORKING |           |           |  |
| APPROVED BY | CHECKED BY | DRAWN BY | FINISH            | PRESION | GENRAL | FINISH | THICKNESS   | THICKNESS | THICKNESS | THICKNESS | THICKNESS         | THICKNESS | THICKNESS | THICKNESS | THICKNESS     | THICKNESS | THICKNESS |  |
| O.C.K       | J.Y.H      | S.D.W    | 0.5-6             | ±0.05   | ±0.1   | 1-3    | ±0.1        | ±0.1      | ±0.1      | ±0.1      | ±0.1              | ±0.1      | ±0.1      | ±0.1      | ±0.1          | ±0.1      | ±0.1      |  |
|             |            |          | 6-30              | ±0.1    | ±0.2   | 3-10   | ±0.1        | ±0.1      | ±0.1      | ±0.1      | ±0.1              | ±0.1      | ±0.1      | ±0.1      | ±0.1          | ±0.1      | ±0.1      |  |
|             |            |          | 30-120            | ±0.15   | ±0.3   | 3-10   | ±0.1        | ±0.1      | ±0.1      | ±0.1      | ±0.1              | ±0.1      | ±0.1      | ±0.1      | ±0.1          | ±0.1      | ±0.1      |  |
|             |            |          | 120-400           | ±0.2    | ±0.5   | 3-10   | ±0.1        | ±0.1      | ±0.1      | ±0.1      | ±0.1              | ±0.1      | ±0.1      | ±0.1      | ±0.1          | ±0.1      | ±0.1      |  |
|             |            |          | 400-1000          | ±0.3    | ±0.8   | 3-10   | ±0.1        | ±0.1      | ±0.1      | ±0.1      | ±0.1              | ±0.1      | ±0.1      | ±0.1      | ±0.1          | ±0.1      | ±0.1      |  |

| FOOT MASTER® |                | FOOMA®            |            | G-DOK IND. |         |
|--------------|----------------|-------------------|------------|------------|---------|
| SERIES NAME  | GF-SERIES      | DATE              | 2023.08.21 | GSN NO.    | -       |
| PRODUCT NAME | GF-200-BRF-MUD | SCALE             | N/S        | DWG. NO.   | -       |
| PART NAME    | ASSEMBLY       | WEIGHT            | --         | REVISION   | SIZE A3 |
|              |                | GENERAL TOLERANCE | --         | ANGLE      | ▲       |

FOOT MASTER G-DOK IND.