

The Pride of Top Quality  
FOOT MASTER®







---

# 고하중 캐스터

---

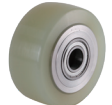
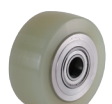

## 바퀴선택에 대한 가이드 : 고하중 캐스터

이미지	구분	바퀴설명	바퀴코드	바퀴외경 mm	바퀴폭 mm	축경 mm	허브길이 mm	허용하중 Kg	베어링 규격
	NYD	- 나일론66(Shore D70) - 볼베어링 2개	NYD-100-48	100	48	20	48	600	6204 ZZ
	MUD	- 주형우레탄(Shore A95) - 알루미늄 코어 - 볼베어링 2개	MUD-100-67	100	67	25	73	650	6005 ZZ
			MUD-125-64	125	64	25	73	750	6005 ZZ
			MUD-150-64	150	64	25	73	800	6205 ZZ
			MUD-200-64	200	64	25	73	850	6205 ZZ
	MCD	- MCL나일론(Shore D80) - 볼베어링 2개	MCD-75-40	75	40	25	40	850	6005 ZZ
			MCD-80-48	80	48	20	48	800	6204 ZZ
			MCD-100-40	100	40	25	40	1,000	6005 ZZ
			MCD-100-48	100	48	20	48	900	6204 ZZ
			MCD-100-67	100	67	25	73	800	6005 ZZ
			MCD-125-40	125	40	25	40	1,100	6005 ZZ
			MCD-125-64	125	64	25	73	900	6005 ZZ
			MCD-125-68	125	68	25	70	1,500	6205 ZZ
			MCD-150-64	150	64	25	73	1,000	6205 ZZ
			MCD-150-68	150	68	30	70	2,200	6206 ZZ
			MCD-200-64	200	64	25	73	1,100	6205 ZZ
			MCD-200-68	200	68	30	70	2,500	6206 ZZ
			MCD-250-64	250	64	25	73	1,300	6205 ZZ
			MCD-250-70	250	70	30	70	2,700	6206 ZZ
MCD-250-78	250	78	35	78	3,500	6210 ZZ			
MCD-300-78	300	78	35	78	4,000	6210 ZZ			
	MCQ	- MCL나일론(Shore D80) - 볼베어링 4개	MCQ-200-100	200	100	50	100	6,000	6210 ZZ
			MCQ-250-100	250	100	50	100	7,000	6210 ZZ
			MCQ-300-100	300	100	50	100	8,000	6210 ZZ
	HUD	- 주형우레탄(Shore A95) - 스틸 코어 - 볼베어링 2개	HUD-100-29	100	29	15	27	200	6202 ZZ
			HUD-110-29	110	29	15	27	200	6202 ZZ
			HUD-150-40	150	40	17	40	400	6203 ZZ
			HUD-200-65	200	65	25	65	1,250	6205 ZZ
			HUD-250-78	250	78	35	78	2,200	6210 ZZ
	HUD	- 주형우레탄(Shore D70) - 스틸 코어 - 볼베어링 2개	HUD-80-48	80	48	20	48	500	6204 ZZ
			HUD-100-48	100	48	20	48	600	6204 ZZ
	HUD	- 주형우레탄(Shore D70) - 알루미늄 코어 - 볼베어링 2개	HUD-75-40	75	40	25	40	400	6005 ZZ
			HUD-100-40	100	40	25	40	550	6005 ZZ
			HUD-125-40	125	40	25	40	700	6005 ZZ
	HUD	- 주형우레탄(Shore A95) - 알루미늄 코어 - 볼베어링 2개	HUD-125-70	125	70	25	70	1,100	6205 ZZ
			HUD-150-68	150	68	30	70	1,500	6206 ZZ
			HUD-200-68	200	68	30	70	2,000	6206 ZZ
	HUQ	- 주형우레탄(Shore A95) - 알루미늄 코어 - 볼베어링 4개	HUD-250-64	250	64	30	70	2,300	6206 ZZ
			HUQ-200-100	200	100	50	100	2,500	6210 ZZ
			HUQ-250-100	250	100	50	100	2,900	6210 ZZ
			HUQ-300-100	300	100	50	100	3,300	6210 ZZ

## 고하중 캐스터

# GF series

**kg** 650~1,300kg    **RoHS**    **°C** -10~90°C

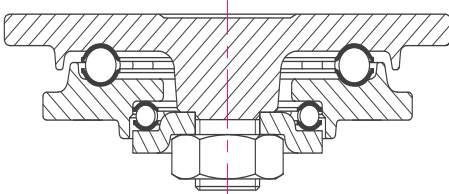

**Brackets:** 단조 플레이트, 강화열처리 시트가 적용된 이중 볼 회전구조, 강력한 용접 프레임, 스틸 탑브레이크 시스템, 볼트너트식 샤프트 체결구조  
**Surface Treatment:** 분체도장, 아연도금

\* 4개당 추천하중 = 1개당 허용하중 × 3

회전형	고정형	회전 브레이크형	고정 브레이크형	바퀴 종류	mm	mm	Kg	mm	mm	mm	mm	
GF-100-ASF	GF-100-ARF	GF-100-BSF	GF-100-BRF	MUD	100	67	650	145	37	159x114	134x86 126x62	13
GF-125-ASF	GF-125-ARF	GF-125-BSF	GF-125-BRF		125	64	750	167	44			
GF-150-ASF	GF-150-ARF	GF-150-BSF	GF-150-BRF		150	64	800	190	52			
GF-200-ASF	GF-200-ARF	GF-200-BSF	GF-200-BRF		200	64	850	257	57			
GF-250-ASF	GF-250-ARF	GF-250-BSF	GF-250-BRF		250	64	1,200	300	61			
GF-100-ASF	GF-100-ARF	GF-100-BSF	GF-100-BRF	MCD	100	67	800	145	37	159x114	134x86 126x62	13
GF-125-ASF	GF-125-ARF	GF-125-BSF	GF-125-BRF		125	64	900	167	44			
GF-150-ASF	GF-150-ARF	GF-150-BSF	GF-150-BRF		150	64	1,000	190	52			
GF-200-ASF	GF-200-ARF	GF-200-BSF	GF-200-BRF		200	64	1,100	257	57			
GF-250-ASF	GF-250-ARF	GF-250-BSF	GF-250-BRF		250	64	1,300	300	61			

### 선택사항

제품코드	MUD	MCD	-FRN	-4DL		
제품특징	주형우레탄(A95)	MCL일론(D80)	브레이크방향	회전 / 고정 변환장치		
적용모델	100 ~ 250	100 ~ 250	150 ~ 250	100 ~ 250		

## 고하중 캐스터 GXT series

**kg** 500~2,700kg    **RoHS**    **°C** -10~90°C

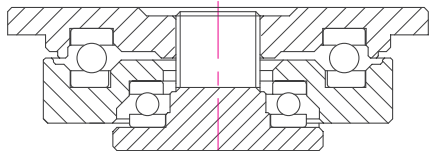

GXT(80~100)

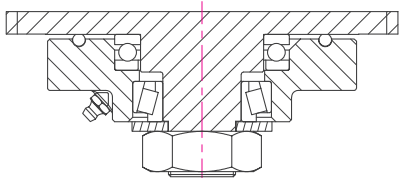

GXT(125~250)

**Brackets:** 단조 플레이트, 2열의 스러스트베어링 적용으로 고하중에 최적화된 회전구조(125~250시리즈: 스러스트+테이퍼롤러베어링), 강력한 용접 프레임, 핸들 브레이크 시스템, 특수형태의 샤프트 적용으로 부드러운 회전력 강화

**Surface Treatment:** 분체도장, 아연도금

\* 4개당 추천하중 = 1개당 허용하중 × 3

회전형	고정형	회전 브레이크형	바퀴 종류	mm	mm	Kg	mm	mm	mm	mm	
GXT-80-ASF	GXT-80-ARF	GXT-80-BSF	HUD	80	48	500	120	40	100x85	80x60	9
GXT-100-ASF	GXT-100-ARF	GXT-100-BSF		100	48	600	140	40			
GXT-125-ASF	GXT-125-ARF	GXT-125-BSF		125	70	1,100	170	77.5			
GXT-150-ASF	GXT-150-ARF	GXT-150-BSF		150	68	1,500	224	48	175x140	148x111 132x99	14
GXT-200-ASF	GXT-200-ARF	GXT-200-BSF		200	68	2,000	275	60			
GXT-250-ASF	GXT-250-ARF	GXT-250-BSF		250	64	2,300	310	75			
GXT-80-ASF	GXT-80-ARF	GXT-80-BSF	MCD	80	48	800	120	40	100x85	80x60	9
GXT-100-ASF	GXT-100-ARF	GXT-100-BSF		100	48	900	140	40			
GXT-125-ASF	GXT-125-ARF	GXT-125-BSF		125	70	1,500	170	77.5			
GXT-150-ASF	GXT-150-ARF	GXT-150-BSF		150	70	2,200	200	80	175x140	148x111 132x99	14
GXT-200-ASF	GXT-200-ARF	GXT-200-BSF		200	70	2,500	260	75			
GXT-250-ASF	GXT-250-ARF	GXT-250-BSF		250	70	2,700	310	75			
GXT-80-ASF	GXT-80-ARF	GXT-80-BSF	NYD	80	48	800	120	40	100x85	80x60	9
GXT-100-ASF	GXT-100-ARF	GXT-100-BSF		100	48	900	140	40			
GXT-200-ASF	GXT-200-ARF	GXT-200-BSF		200	70	2,500	260	75			

### 선택사항

제품코드	HUD	HUD	MCD	NYD		
제품특징	주형우레탄(D70)	주형우레탄(A95)	MCL나일론(D80)	고성능나일론(D70)		
적용모델	80 ~ 100	125 ~ 250	80 ~ 250	80 ~ 200		

고하중 캐스터

GXT series



450~600kg



-10~90°C

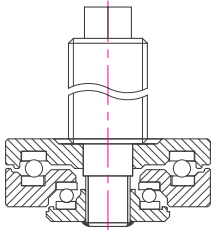

**Brackets:** 단조볼트, 2열의 스톱베어링 적용으로 고하중에 최적화된 회전구조, 강력한 용접 프레임, 핸들 브레이크 시스템, 특수형태의 샤프트 적용으로 부드러운 회전력 강화

**Surface Treatment:** 분체도장, 아연도금

\* 4개당 추천하중 = 1개당 허용하중 × 3

회전형	회전 브레이크형	바퀴 종류	mm	mm	Kg	mm	mm	mm	mm	mm
GXT-80-ASS	GXT-80-BSS	HUD	80	48	500	120	40	TM32-4산 or M36x4.0P	115+15	20
GXT-100-ASS	GXT-100-BSS		100	48	600	140	40			
GXT-100-ASS	GXT-100-BSS		100	48	600	140	40	TW38-4산	101.6+12.7	19
GXT-75-ASS	GXT-75-BSS	MCD	75	48	450	108	25	M24x3.0P	102.3+12.7	17
GXT-80-ASS	GXT-80-BSS		80	48	500	120	40	TM32-4산 or M36x4.0P	115+15	20
GXT-100-ASS	GXT-100-BSS		100	48	600	140	40			
GXT-100-ASS	GXT-100-BSS		100	48	600	140	40	TW38-4산	101.6+12.7	19
GXT-75-ASS	GXT-75-BSS	NYD	75	48	450	108	25	M24x3.0P	102.3+12.7	17
GXT-80-ASS	GXT-80-BSS		80	48	500	120	40	TM32-4Thread or M36x4.0P	115+15	20
GXT-100-ASS	GXT-100-BSS		100	48	600	140	40			
GXT-100-ASS	GXT-100-BSS		100	48	600	140	40	TW38-4산	101.6+12.7	19

선택사항

제품코드	HUD	MCD	NYD			
제품특징	주형우레탄(D70)	MCL나일론(D80)	나일론66(D70)			
적용모델	80 ~ 100	75 ~ 100	75 ~ 100			

고하중 캐스터

# GXTT series

**kg** 800~2,300kg    **RoHS**    **°C** -10~90°C

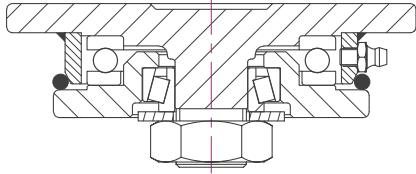



**Brackets:** 단조 플레이트, 슬러스트+테이퍼롤러베어링 적용으로 고하중에 최적화된 회전구조, 그리스 니플 적용, 강력한 용접 프레임, 핸들 브레이크 시스템, 볼트너트식 샤프트 체결구조

**Surface Treatment:** 분체도장, 아연도금

\* 4개당 추천하중 = 1개당 허용하중 × 3

회전형	고정형	회전 브레이크형	고정 브레이크형	바퀴 종류	 mm	 mm	 Kg	 mm	 mm	 mm	 mm	 mm
GXTT-75-ASF	GXTT-75-ARF	GXTT-75-BSF	GXTT-75-BRF	HUD	75	40x2	800	125	45	[SF]	105x80	13
GXTT-100-ASF	GXTT-100-ARF	GXTT-100-BSF	GXTT-100-BRF		100	40x2	1,100	150	50	140x110 [RF]		
GXTT-125-ASF	GXTT-125-ARF	GXTT-125-BSF	GXTT-125-BRF		125	40x2	1,400	175	55	140x117		
GXTT-75-ASF	GXTT-75-ARF	GXTT-75-BSF	GXTT-75-BRF	MCD	75	40x2	1,700	125	45	[SF]	105x80	13
GXTT-100-ASF	GXTT-100-ARF	GXTT-100-BSF	GXTT-100-BRF		100	40x2	2,000	150	50	140x110 [RF]		
GXTT-125-ASF	GXTT-125-ARF	GXTT-125-BSF	GXTT-125-BRF		125	40x2	2,300	175	55	140x117		

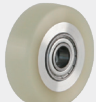
**선택사항**

						
제품코드	HUD	MCD				
제품특징	주형우레탄(D70)	MCL일론(D80)				
적용모델	75 ~ 125	75 ~ 125				

고하중 캐스터

GXTT series

800~1700kg RoHS -10~90°C

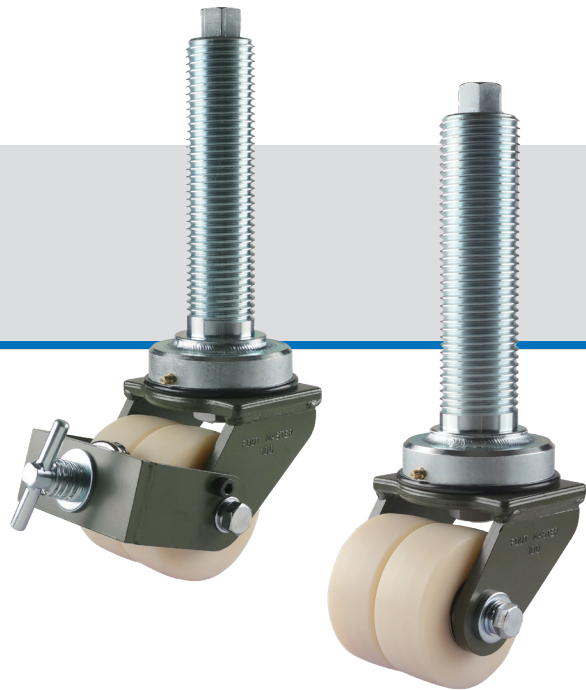
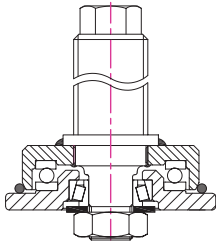

**Brackets:** 단조볼트, 스테인리스+테이퍼롤러베어링 적용으로 고하중에 최적화된 회전구조, 그리스 니플 적용, 강력한 용접 프레임, 핸들 브레이크 시스템, 볼트너트식 샤프트 체결구조

**Surface Treatment:** 분체도장, 아연도금

\* 4개당 추천하중 = 1개당 허용하중 × 3

회전형	회전 브레이크형	바퀴 종류	mm	mm	Kg	mm	mm	mm	mm	mm
GXTT-75-ASS	GXTT-75-BSS	HUD	75	40x2	800	128,5	45	TR36x5P	174+20	24
					800			M42x4.5P	130+20	30
					800			M52x5.0P	200+20	27
GXTT-100-ASS	GXTT-100-BSS		100	40x2	1,000	153,5	50	TR36x5P	174+20	24
					1,100			M42x4.5P	130+20	30
					1,100			M52x5.0P	200+20	27
GXTT-125-ASS	GXTT-125-BSS	125	40x2	1,000	178,5	55	TR36x5P	174+20	24	
				1,400			M42x4.5P	130+20	30	
				1,400			M52x5.0P	200+20	27	
GXTT-75-ASS	GXTT-75-BSS	MCD	75	40x2	1,000	128,5	45	TR36x5P	174+20	24
					1,400			M42x4.5P	130+20	30
					1,700			M52x5.0P	200+20	27
GXTT-100-ASS	GXTT-100-BSS		100	40x2	1,000	153,5	50	TR36x5P	174+20	24
					1,400			M42x4.5P	130+20	30
					1,700			M52x5.0P	200+20	27
GXTT-125-ASS	GXTT-125-BSS	125	40x2	1,000	178,5	55	TR36x5P	174+20	24	
				1,400			M42x4.5P	130+20	30	
				1,700			M52x5.0P	200+20	27	

선택사항

제품코드	HUD	MCD				
제품특징	주형우레탄(D70)	MCL-일론(D80)				
적용모델	75 ~ 125	75 ~ 125				

## 고하중 캐스터

# GXTD series

**kg** 400~8,000kg    **RoHS**    **°C** -10~90°C

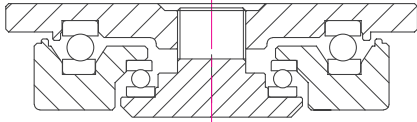

GXTD(100~200)

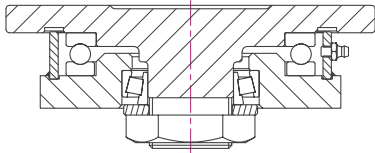

GXTD(250~300)

**Brackets:** 단조 플레이트, 2열의 스톱스트베어링 적용으로 고하중에 최적화된 회전구조(250/300시리즈: 스톱스트+테이퍼롤러베어링), 그리스 니플 적용, 강력한 용접 프레임, 볼트너트식 샤프트 체결구조  
**Surface Treatment:** 분체도장, 아연도금

\* 4개당 추천하중 = 1개당 허용하중 × 3

회전형	고정형	바퀴 종류	mm	mm	Kg	mm	mm	mm	mm	mm
GXTD-100-ASF	GXTD-100-ARF	HUD	100	29x2	400	156	35	140x112	110x75 105x80	11
GXTD-110-ASF	GXTD-110-ARF		110	29x2	400	156	30	112x112	88x88	9
GXTD-150-ASF	GXTD-150-ARF		150	40x2	800	200	35	145x130	115x100	11
GXTD-200-ASF	GXTD-200-ARF		200	65x2	2,500	265	50	210x210	170x170	17
GXTD-250-ASF	GXTD-250-ARF		250	78x2	4,500	330	70	255x215	210x160	18
GXTD-300-ASF	GXTD-300-ARF		300	78x2	5,200	390	80			
GXTD-250-ASF	GXTD-250-ARF	MCD	250	78x2	7,000	330	70	255x215	210x160	18
GXTD-300-ASF	GXTD-300-ARF		300	78x2	8,000	390	80			

### 선택사항

제품코드	HUD	MCD				
제품특징	주형우레탄(A95)	MCL일론(D80)				
적용모델	100 ~ 300	250 ~ 300				



고하중 캐스터

# UGXT series

**kg** 2,500~8,000kg    **RoHS**    **°C** -10~90°C

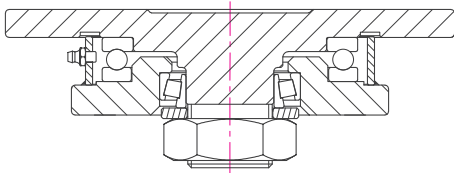



**Brackets:** 단조 플레이트, 스테인리스+테이퍼롤러베어링 적용으로 고하중에 최적화된 회전구조, 그리스 니플 적용, 강력한 용접 프레임, 핸들 브레이크 시스템, 특수형태의 샤프트 적용으로 부드러운 회전력 강화

**Surface Treatment:** 분체도장, 아연도금

\* 4개당 추천하중 = 1개당 허용하중 × 3

회전형	고정형	회전 브레이크형	바퀴 종류	 mm	 mm	 Kg	 mm	 mm	 mm	 mm	 mm
UGXT-200-ASF	UGXT-200-ARF	UGXT-200-BSF	HUQ	200	100	2,500	280	75	255x215	210x160	18
UGXT-250-ASF	UGXT-250-ARF	UGXT-250-BSF		250	100	2,900	330	80			
UGXT-300-ASF	UGXT-300-ARF	UGXT-300-BSF		300	100	3,300	380	90			
UGXT-200-ASF	UGXT-200-ARF	UGXT-200-BSF	MCQ	200	100	6,000	280	75	255x215	210x160	18
UGXT-250-ASF	UGXT-250-ARF	UGXT-250-BSF		250	100	7,000	330	80			
UGXT-300-ASF	UGXT-300-ARF	UGXT-300-BSF		300	100	8,000	380	90			

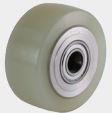
**선택사항**

						
제품코드	HUQ	MCQ				
제품특징	주형우레탄(A95)	MCL일론(D80)				
적용모델	200 ~ 300	200 ~ 300				

